

MM 165-220



Motoniveladora
CATALAGO DE
PARTES



GENERAL

Chasis delantero	pág. 4
Chasis central	pág. 10
Montaje de motor 1 - MM220	pág. 12
Montaje de motor 2 - MM220	pág. 14
Montaje de motor 1 - MM165	pág. 16
Montaje de motor 2 - MM165	pág. 18
Eje delantero	pág. 20
Eje trasero	pág. 22
Núcleo de diferencial 1	pág. 24
Núcleo de diferencial 2	pág. 26
Reductor del diferencial	pág. 28
Caja tandem	pág. 30
Caliper de freno	pág. 32
Hoja niveladora y círculo de rotación	pág. 34
Conexión de caja de transmisión 1 - MM220	pág. 36
Conexión de caja de transmisión 2 - MM220	pág. 38
Conexión de caja de transmisión 1 - MM165	pág. 40
Conexión de caja de transmisión 2 - MM165	pág. 42
Capó 1	pág. 44
Capó 2	pág. 46
Plataforma de cabina 1	pág. 48
Plataforma de cabina 2	pág. 50
Palanca de freno de mano	pág. 52
Control de freno 1	pág. 54
Control de freno 2	pág. 56
Comandos de control 1	pág. 58
Comandos de control 2	pág. 60
Comandos de control 3	pág. 62
Sistema hidráulico de trabajo 1	pág. 64
Sistema hidráulico de trabajo 2	pág. 66
Sistema hidráulico de trabajo 3	pág. 68
Sistema hidráulico de trabajo 4	pág. 70
Sistema hidráulico de trabajo 5	pág. 75
Sistema hidráulico de trabajo 6	pág. 74
Sistema hidráulico de trabajo 7	pág. 76
Sistema hidráulico de trabajo 8	pág. 78
Sistema hidráulico de trabajo 9	pág. 80
Sistema hidráulico de trabajo 10	pág. 82
Sistema de dirección hidráulico 1	pág. 84
Sistema de dirección hidráulico 2	pág. 86
Columna de dirección completa	pág. 88
Tanque de aceite	pág. 90
Cabina	pág. 92
Sistema eléctrico	pág. 94

1- Chasis delantero

CODIGO DOWEL	PIEZA	DESCRIPCION	CANT.
MM165.01.001	1	CHASIS DELANTERO	1
	2	PERNO M12x25	16
	3	ARANDELA 12	16
MM165.01.004	4	ALEMITE M10x1	2
MM165.01.005	5	PLACA TAPA TRASERA	1
MM165.01.006	6	JUNTA	2
MM165.01.007	7	PLACA TAPA DELANTERA	1
MM165.01.008	8	PERNO M8x20	34
	9	ARANDELA 8	34
	10	ARANDELA	341
MM165.01.011	11	TAPA DELANTERA CHASIS	1
MM165.01.012	12	TAPA CENTRAL CHASIS	1
MM165.01.013	13	TAPA TRASERA CHASIS	1

1- Chasis delantero

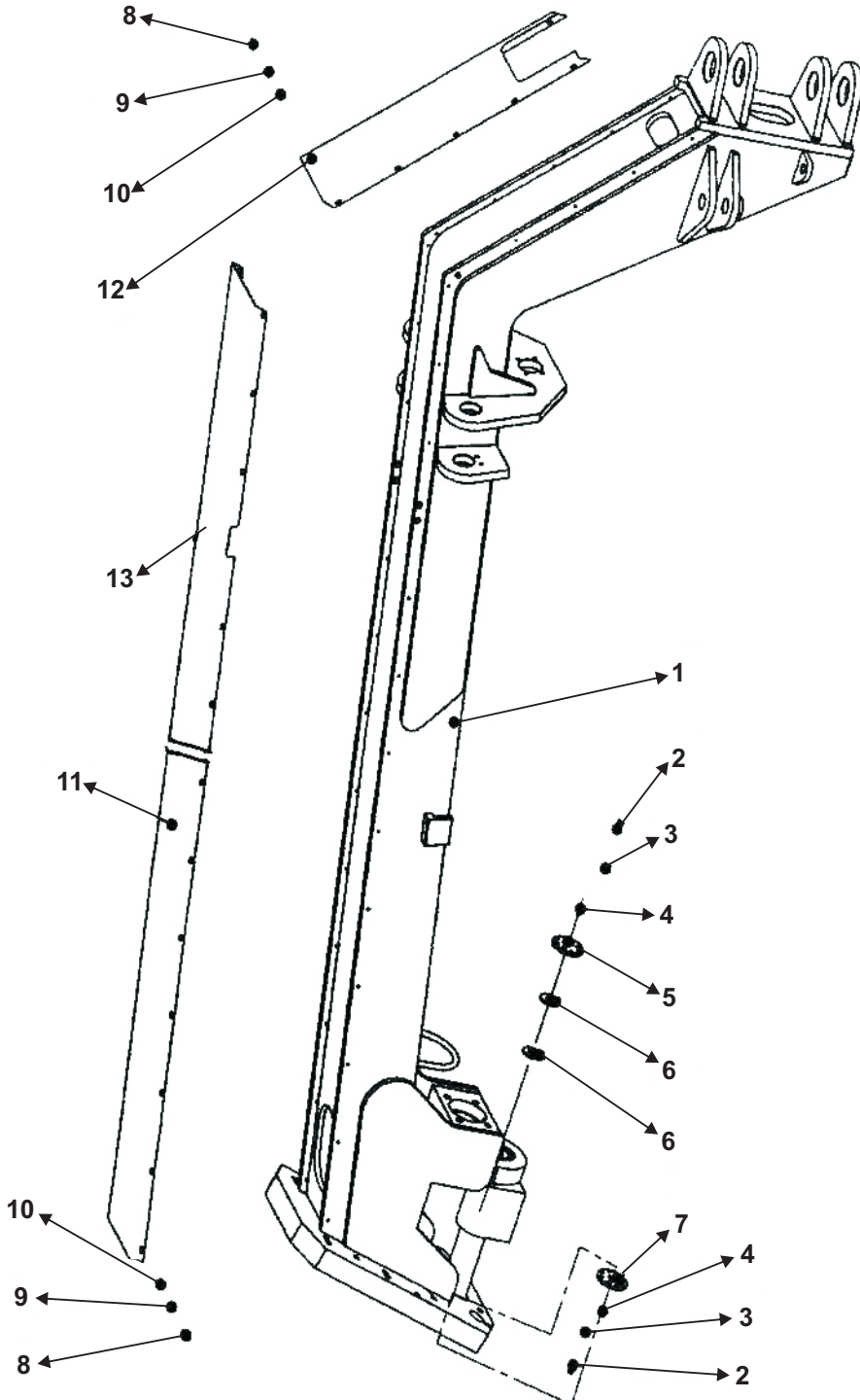

2- Chasis delantero

CODIGO DOWEL	PIEZA	DESCRIPCION	CANT.
	1	TORNILLO M10x30	32
	2	ARANDELA 10	32
MM165.02.003	3	ARANDELA SOPORTE	4
MM165.02.004	4	ALEMITE M8X1-60	2
MM165.02.005	5	EJE UNION CHASIS SUPERIOR	1
MM165.02.006	6	BUJE OSCILANTE	2
MM165.02.007	7	MANGA ESPACIADORA	1
MM165.02.008	8	PLACA TAPA DE EJE	1
	9	ARANDELA 12	3
	10	PERNO M12x35	3
MM165.02.011	11	EJE UNION CHASIS INFERIOR	1
MM165.02.012	12	PLACA SEGURO EJE	1
	13	ARANDELA 20	2
	14	PERNO M20x25	2

2- Chasis delantero

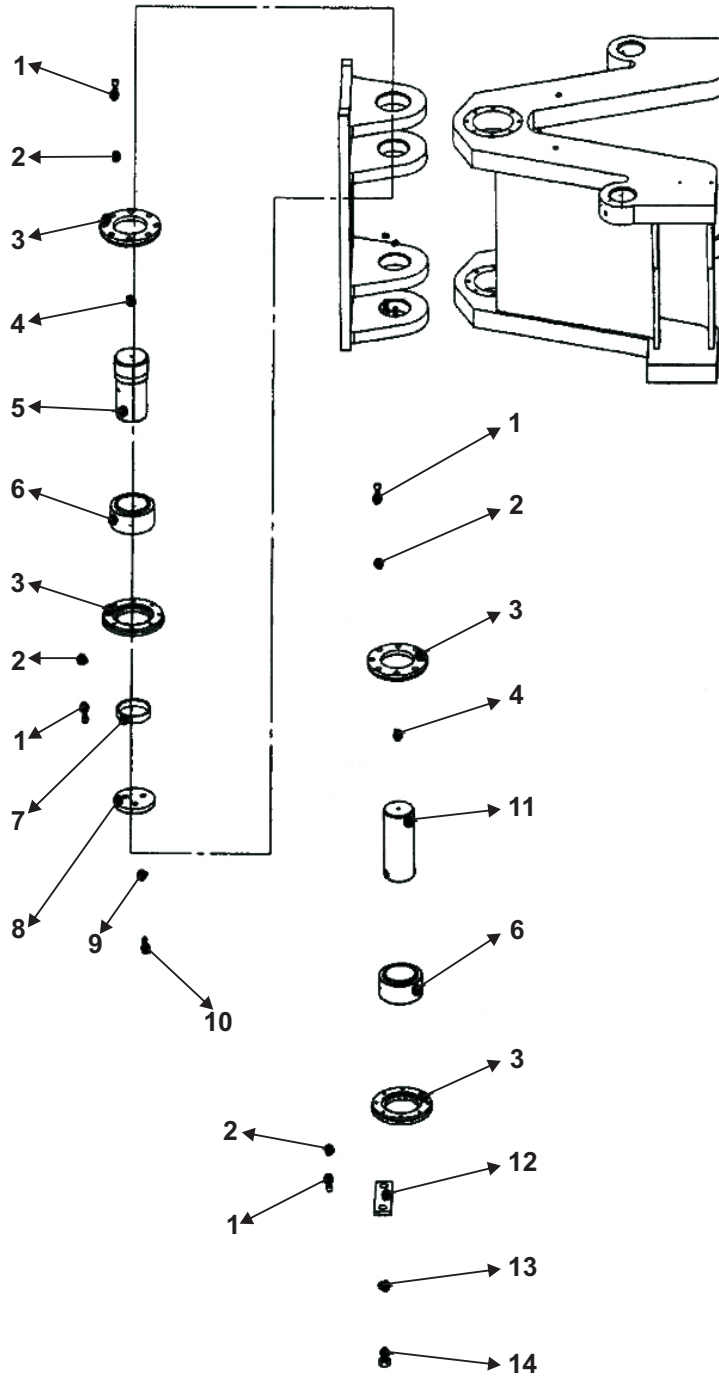

3- Chasis delantero

CODIGO DOWEL	PIEZA	DESCRIPCION	CANT.
MM165.03.001	1	BRAZO PIVOT	1
MM165.03.002	2	BUJE BRAZO PIVOT	8
MM165.01.004	3	ALEMITE	6
MM165.03.004	4	HORQUILLA CILINDRO ELEV HOJA	2
MM165.03.005	5	BUJE DE HORQUILLA	4
MM165.03.006	6	EJE DE BRAZO PIVOT	2
	7	ARANDELA 12	8
	8	PERNO M12x25	4
MM165.03.009	9	PLACA SOPORTE POSICION	1
MM165.03.010	10	BUJE DE PLACA SOPORTE	2
MM165.03.011	11	EJE DE PLACA	2
MM165.03.012	12	PERNO M12x20	4
MM165.03.013	13	BRAZO PIVOT	1
MM165.03.014	14	TAPA HORQUILLA	2
	15	ARANDELA 10	8
	16	PERNO M10x25	8

3- Chasis delantero

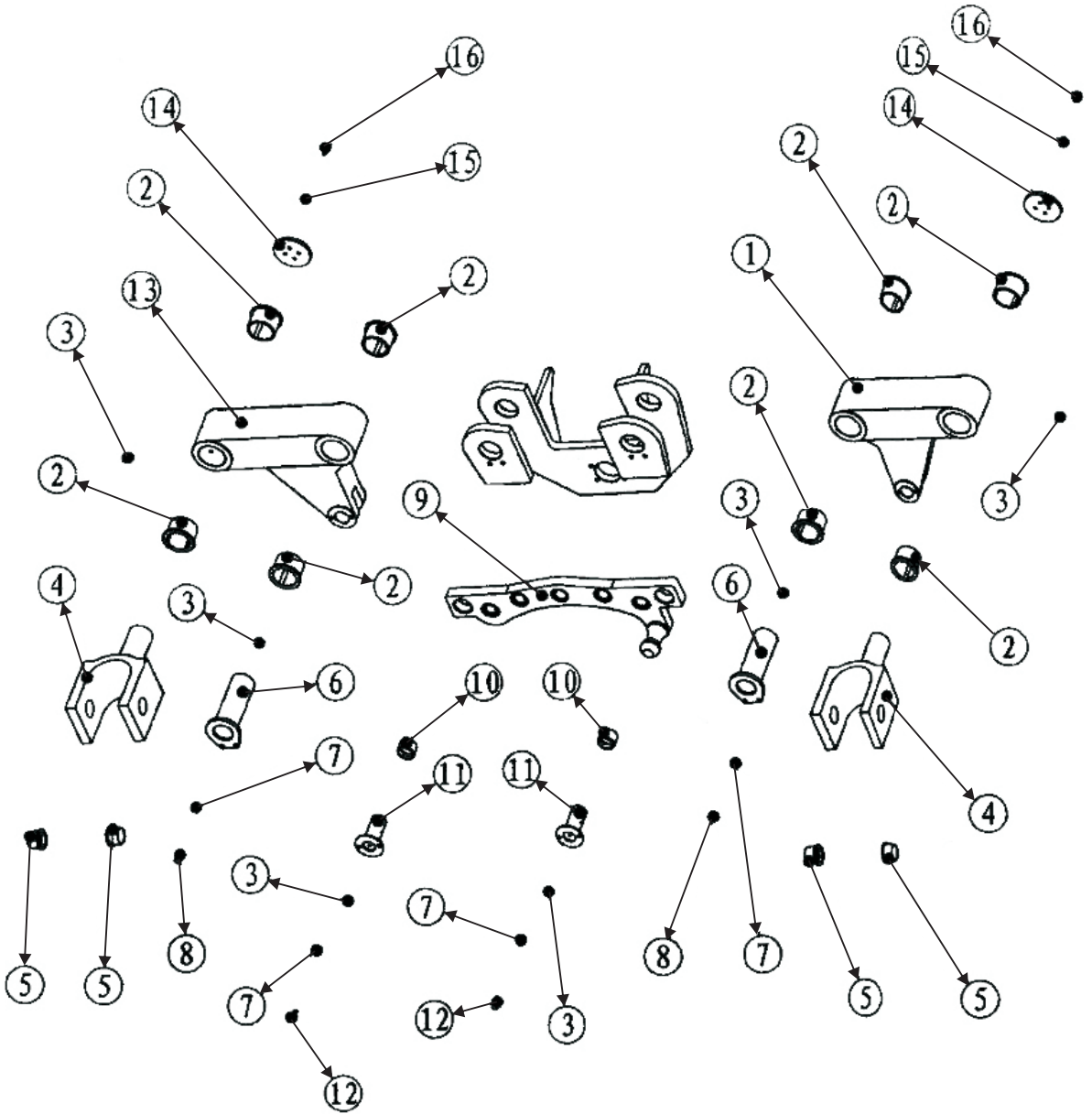

4- Chasis central

CODIGO DOWEL	PIEZA	DESCRIPCION	CANT.
MM165.04.001	1	CHASIS CENTRAL	1
MM165.04.002	2	PLACA LATERAL CHASIS	2
	3	ARANDELA 6	36
	4	ARANDELA 6	8
	5	PERNO M6x20	16
MM165.04.016	16	TRABA DE ARTICULACION	1
	18	ARANDELA 30	2
MM165.04.020	20	PERNO EJE	1
MM165.04.021	21	PERNO EJE	1
MM165.01.004	22	ALEMITE M10x1	2

4- Chasis central

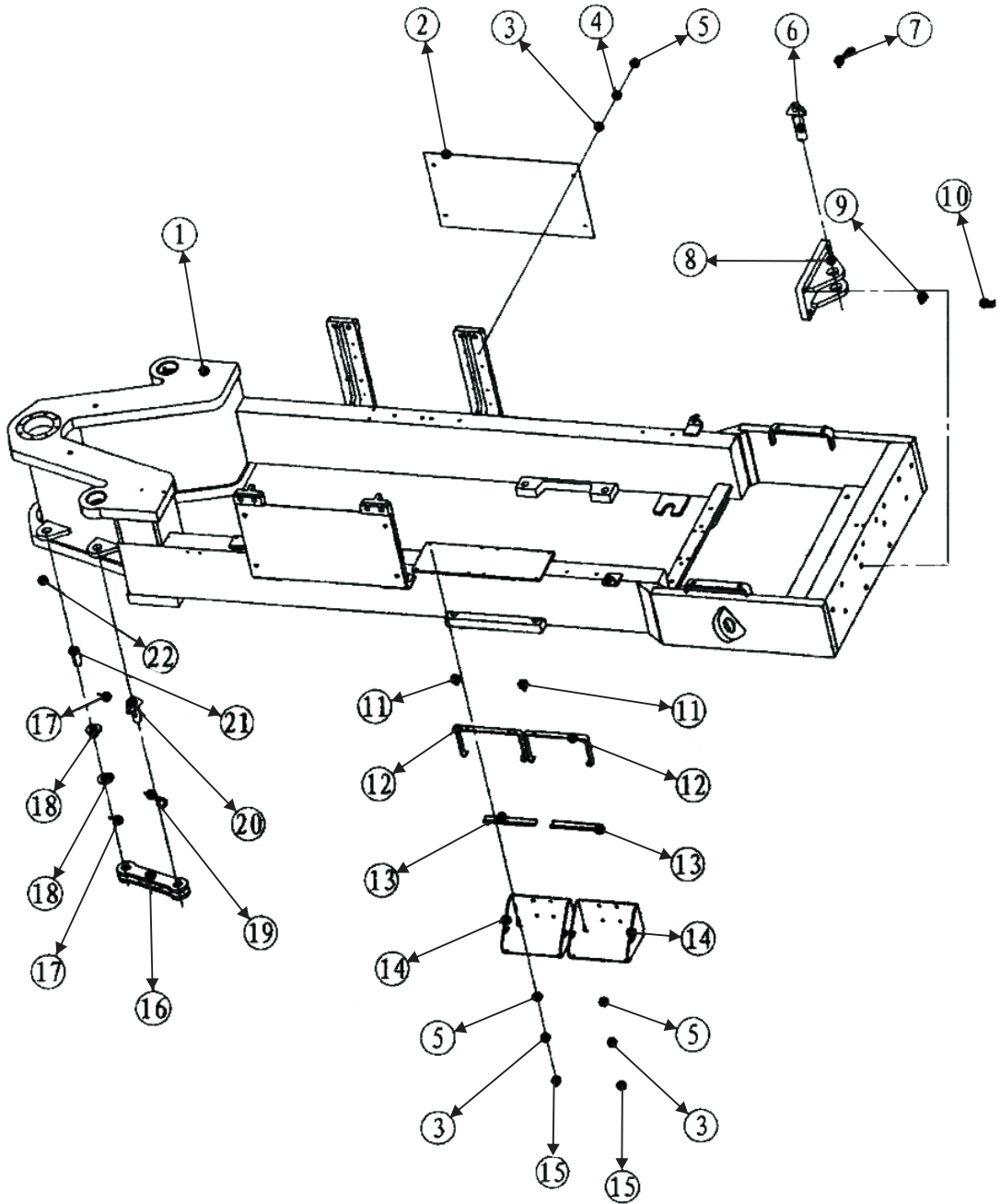

5- Montajes de motor 1 - MM220

CODIGO DOWEL	PIEZA	DESCRIPCION	CANT.
	1	MOTOR CUMMINS 6BTA5.9-C180	1
MM220.05.002	2	RADIADOR	1
MM220.05.003	3	VENTILADOR DE MOTOR	1
MM220.05.004	4	ACOPLE DE VENTILADOR	1
	5	BULON M10x1x25	4
	6	ARANDELA 10	8
MM220.05.007	7	TUBO CONECTOR	1
MM220.05.008	8	MANGUERA	1
	9	ABRAZADERA	4
MM220.05.010	10	TUBO DE AIRE	1
MM220.05.011	11	TUBO	2
MM220.05.012	15	MANGUERA	2
MM220.05.013	16	MANGUERA	1
	17	ABRAZADERA	2
	18	MANGUERA	1
	19	MANGUERA	1
MM220.05.021	21	DEFLECTOR DE RADIADOR	1

5- Montajes de motor 1 - MM220

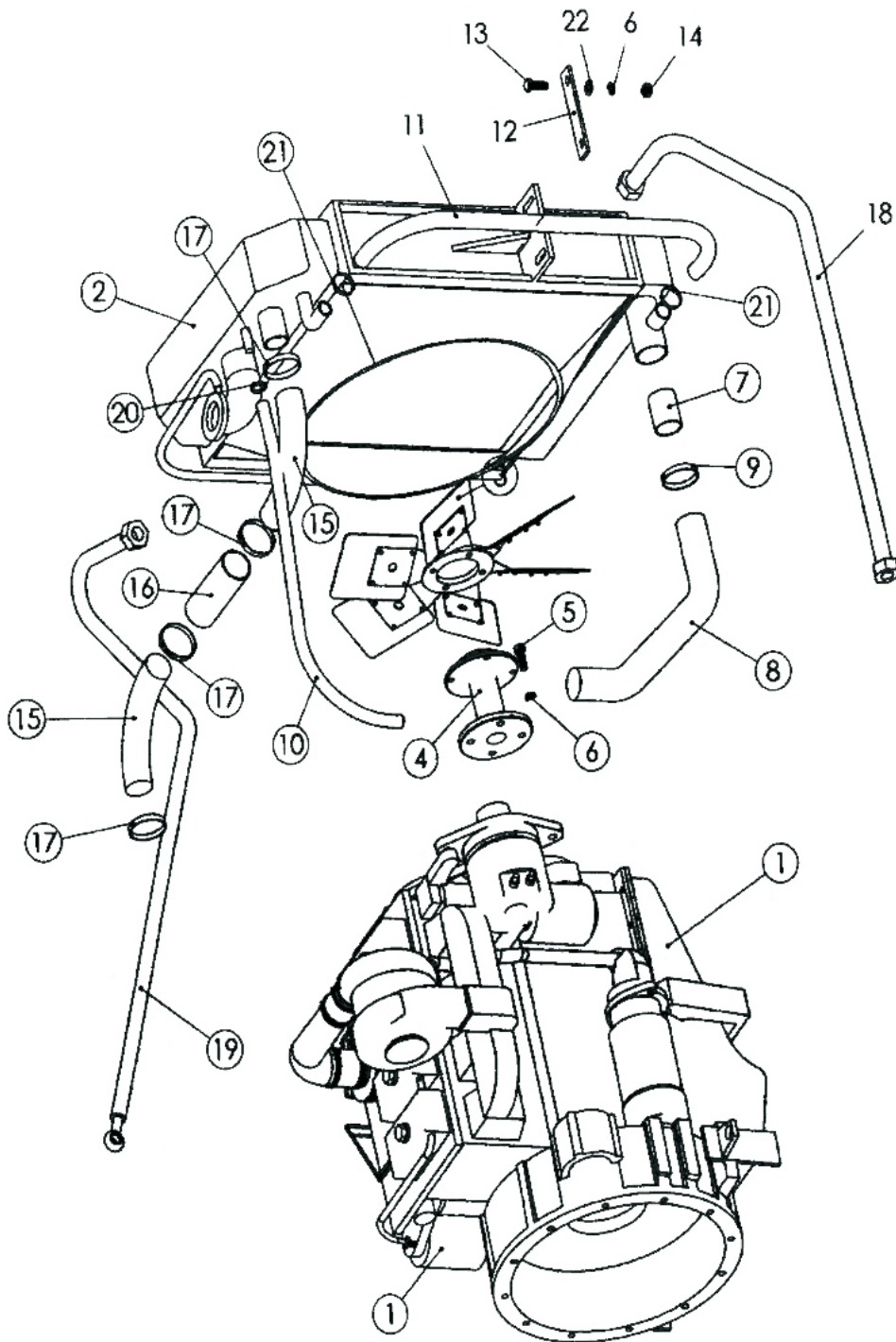

7- Montajes de motor 2 - MM220

CODIGO DOWEL	PIEZA	DESCRIPCION	CANT.
	1	MOTOR	1
MM220.07.002	2	CAÑO DE SILENCIADOR	1
MM220.07.003	3	SILENCIADOR	1
	4	ABRAZADERA	6
MM220.07.005	5	MANGUERA DE CONECCION	1
MM165.07.006	6	CARCASA FILTRO AIRE COMPLETA	1
MM220.07.007	7	CONECTOR DE GOMA	1
MM220.07.008	8	CONECTOR	1
MM220.07.009	9	TUBO CODO AIRE	1
MM220.07.010	10	CONECTOR	1
MM220.07.011	11	SOPORTE	1
MM220.07.015	15	ABRAZADERA TOMA AIRE	1
MM220.07.016	16	SOPORTE FILTRO AIRE	1
MM220.07.018	19	GOMA ASIENTO TOMA AIRE	1
MM165.07.050	50	FILTRO DE AIRE PRIMARIO	1
MM165.07.051	51	FILTRO DE AIRE PRIMARIO	1

7- Montajes de motor 2 - MM220

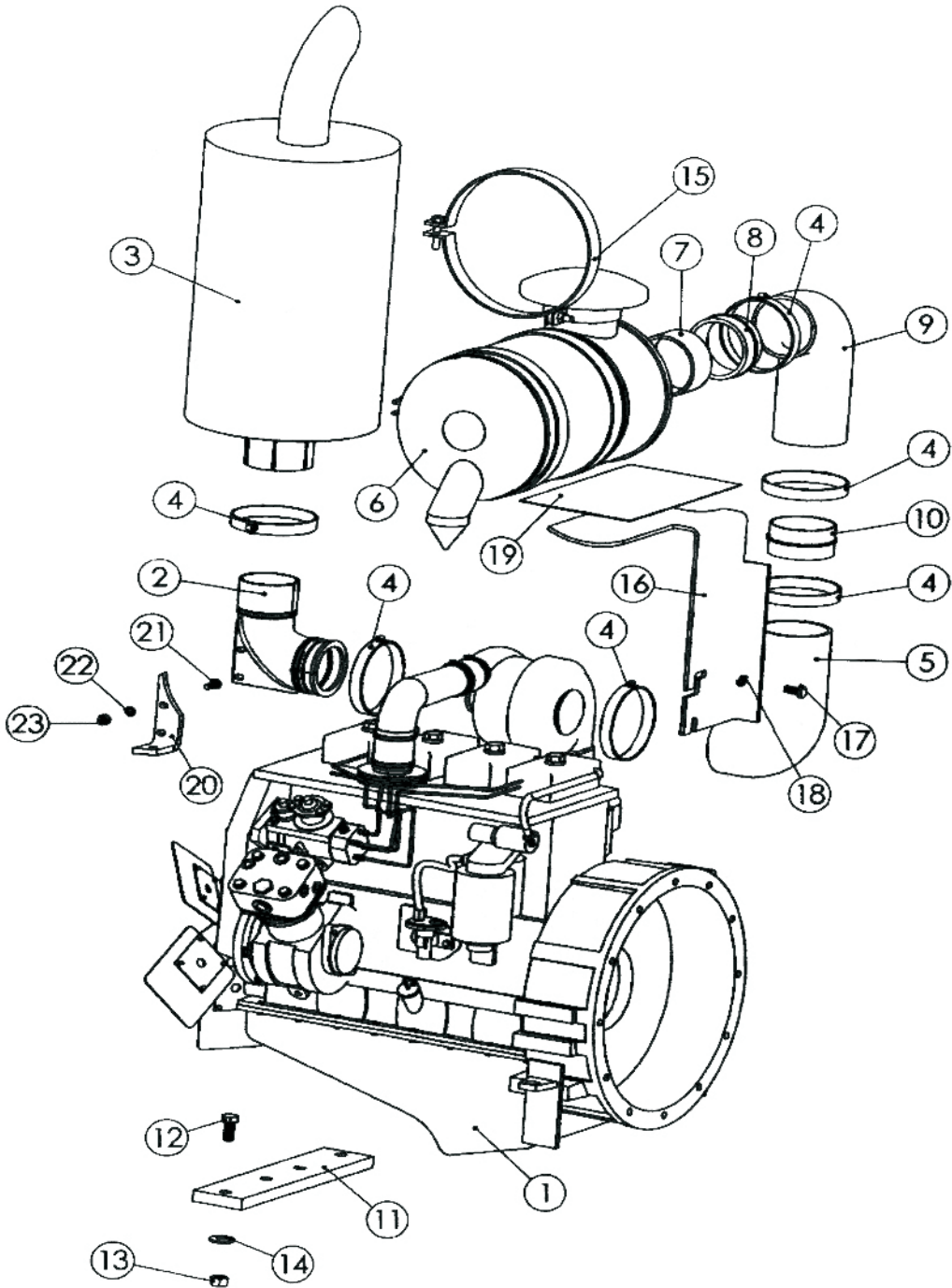

11- Montajes de motor 1 - MM165

CODIGO DOWEL	PIEZA	DESCRIPCION	CANT.
	1	MOTOR	1
MM165.11.002	2	PLACA CONECTORA	1
	5	MANGUERA	1
MM165.11.006	6	TACO SOPORTE MOTOR	2
MM165.11.007	7	MANGUERA	1
	8	ABRAZADERA	4
MM165.11.011	11	VENTILADOR DE MOTOR	1
MM165.11.015	15	RADIADOR	1
MM165.11.017	17	MANGUERA	1
	18	MANGUERA	1
MM165.11.019	19	ABRAZADERA TOMA DE AIRE	2
	24	ABRAZADERA	1
MM165.07.006	26	CARCASA FILTRO AIRE COMPLETA	1
MM165.11.027	27	TUBO CODO AIRE I	1
MM165.11.028	28	TUBO CODO AIRE II	1
MM165.11.029	29	SOPORTE TOMA DE AIRE	1
MM165.07.050	50	FILTRO DE AIRE PRIMARIO	1
MM165.07.051	51	FILTRO DE AIRE PRIMARIO	1

11- Montajes de motor 1 - MM165

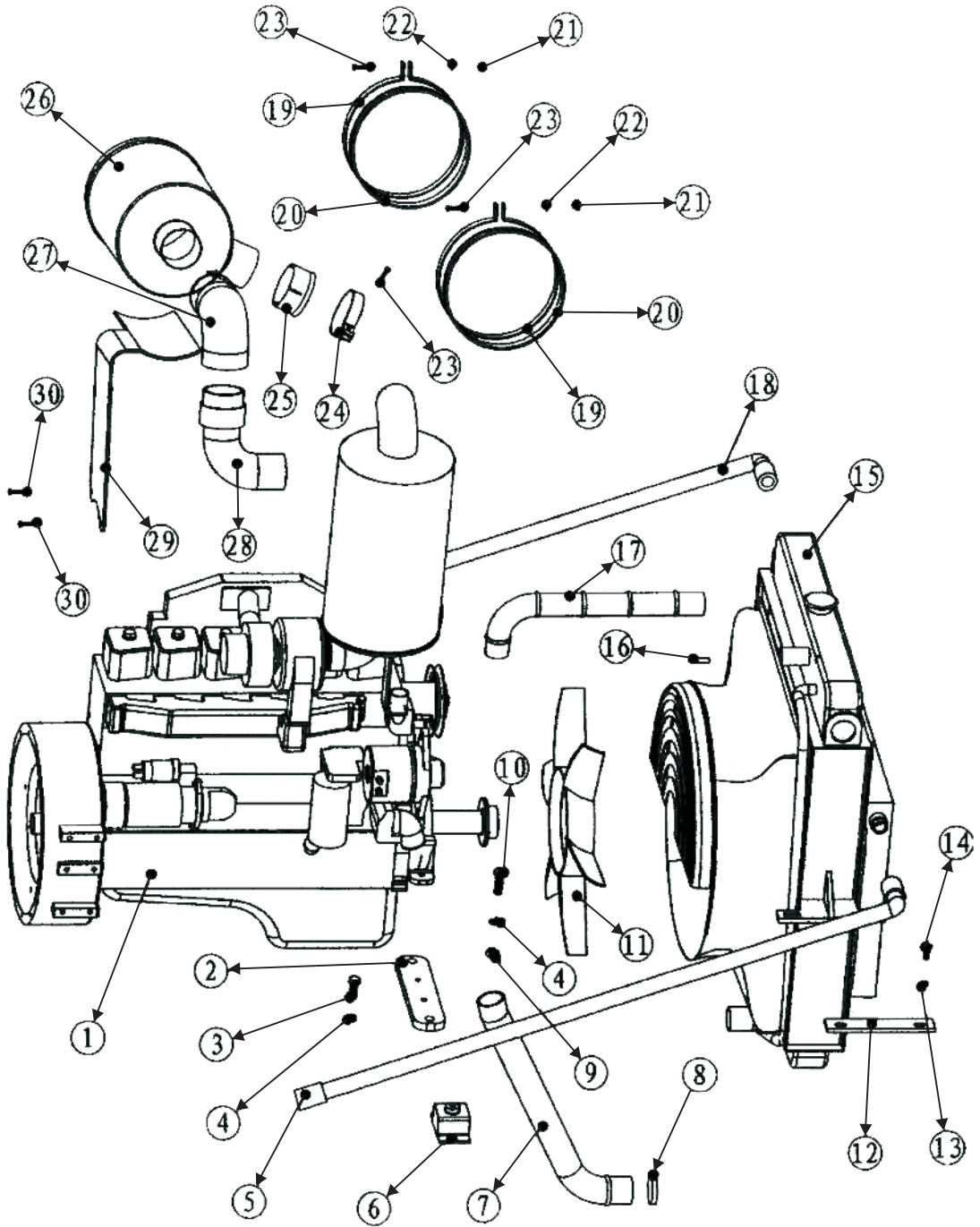

12- Montaje de motor 2 - MM165

CODIGO DOWEL	PIEZA	DESCRIPCION	CANT.
MM165.12.001	1	SILENCIADOR	1
MM165.12.004	4	CONECTOR	2
MM165.12.006	6	MANGUERA	1
MM165.12.013	13	TACO SOPORTE	1
MM165.12.014	14	PLACA SOPORTE	1
MM165.12.015	15	MANGUERA	1
	16	ABRAZADERA	4
MM165.12.017	17	MANGUERA	1
MM165.12.018	18	CONECTOR	1

12- Montaje de motor 2 - MM165

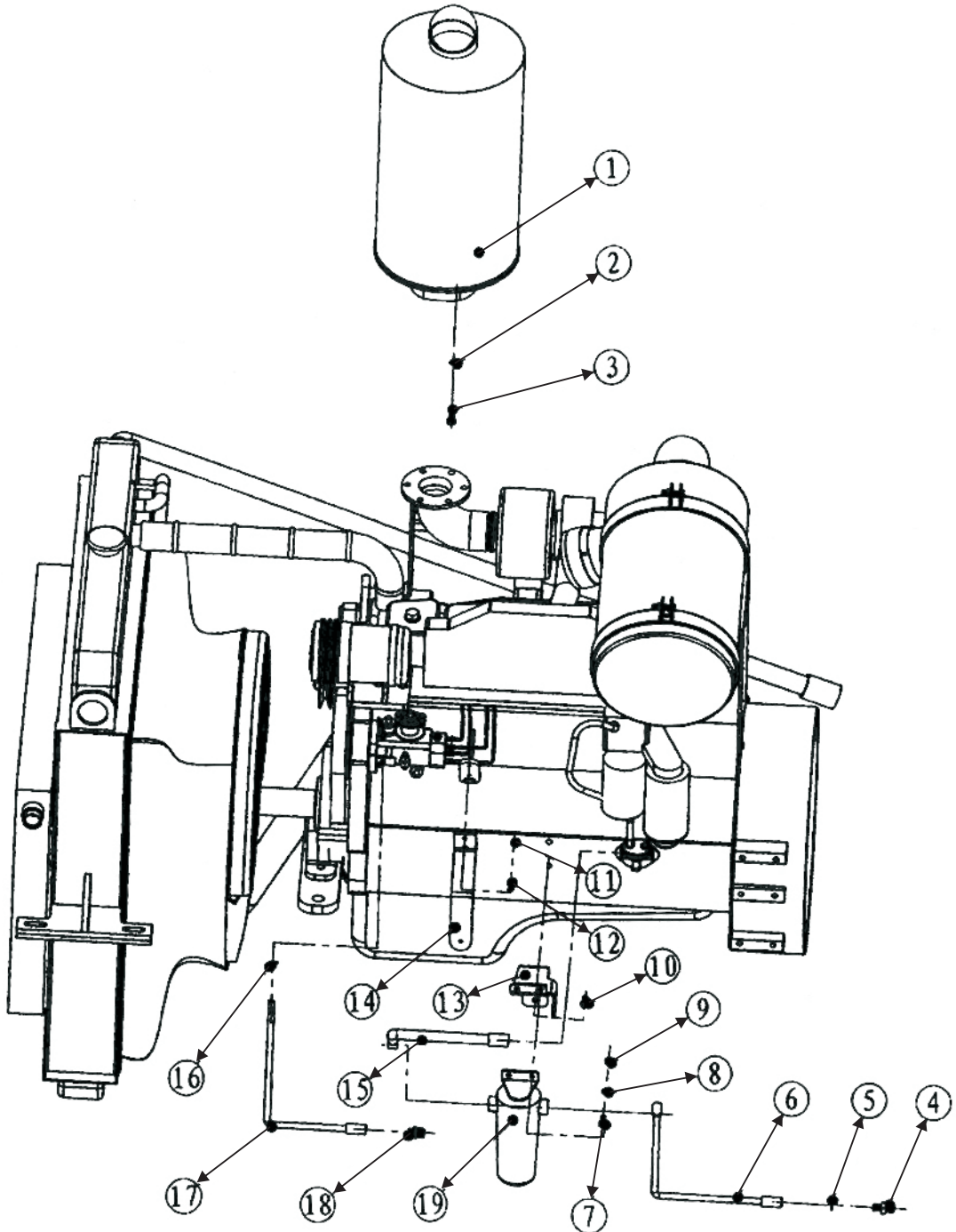

13- Eje delantero

CODIGO DOWEL	PIEZA	DESCRIPCION	CANT.
MM165.13.001	1	EJE DELANTERO COMPLETO	1
MM165.13.002	2	LLANTA	2
MM165.13.003	3	CUBIERTA 17.5-25	2

13- Eje delantero

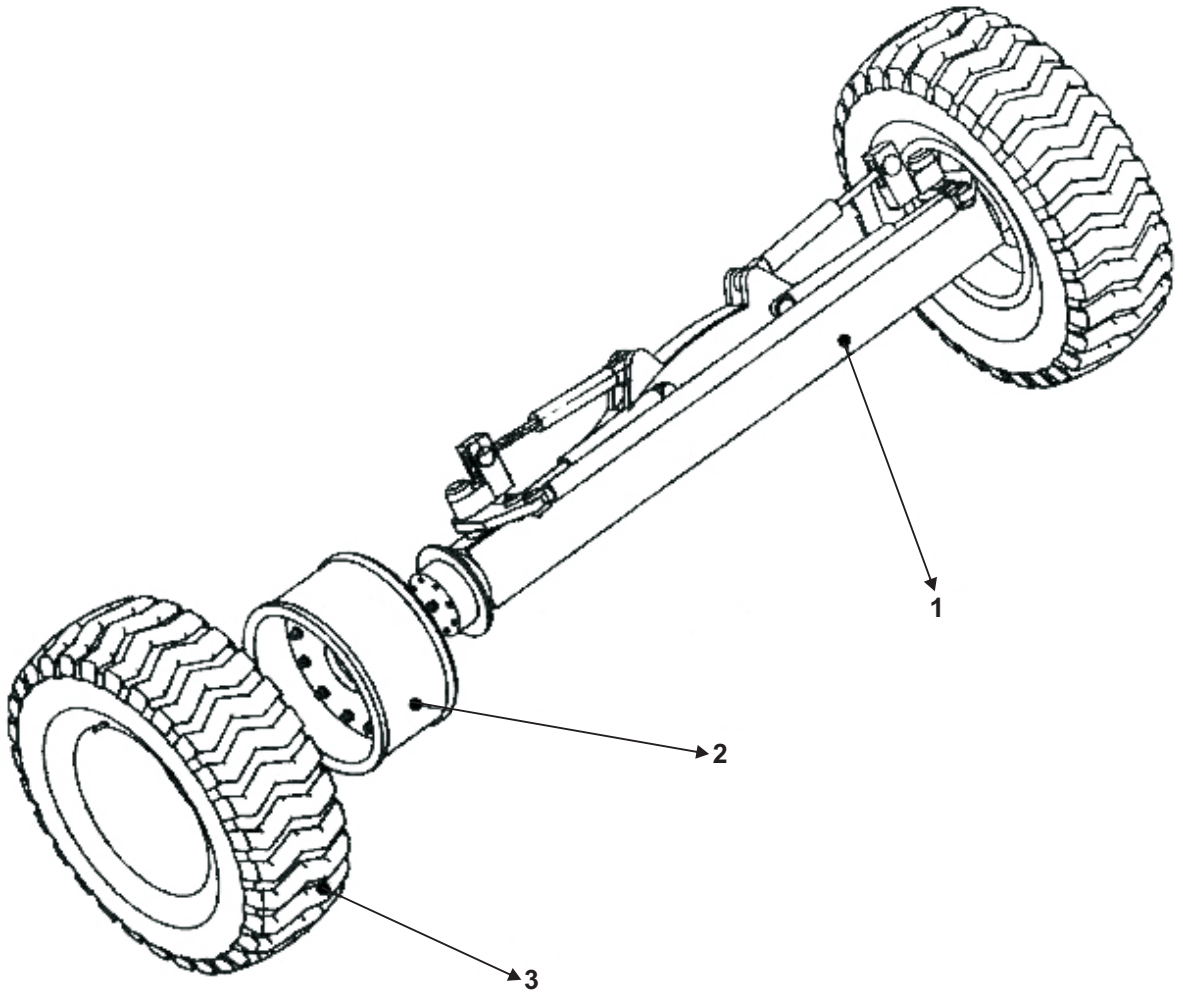

14-1- Eje trasero

CODIGO DOWEL	PIEZA	DESCRIPCION	CANT.
	1	PERNO M24x110	8
	2	ARANDELA 24	8
	3	TUERCA M24	8
MM165.14.004	4	EJE TRASERO COMPLETO	1
MM165.14.005	5	CAJA TANDEM COMPLETA	2
MM165.13.002	6	LLANTA	4
MM165.13.003	7	CUBIERTA 17.5-25	4

14-1- Eje trasero

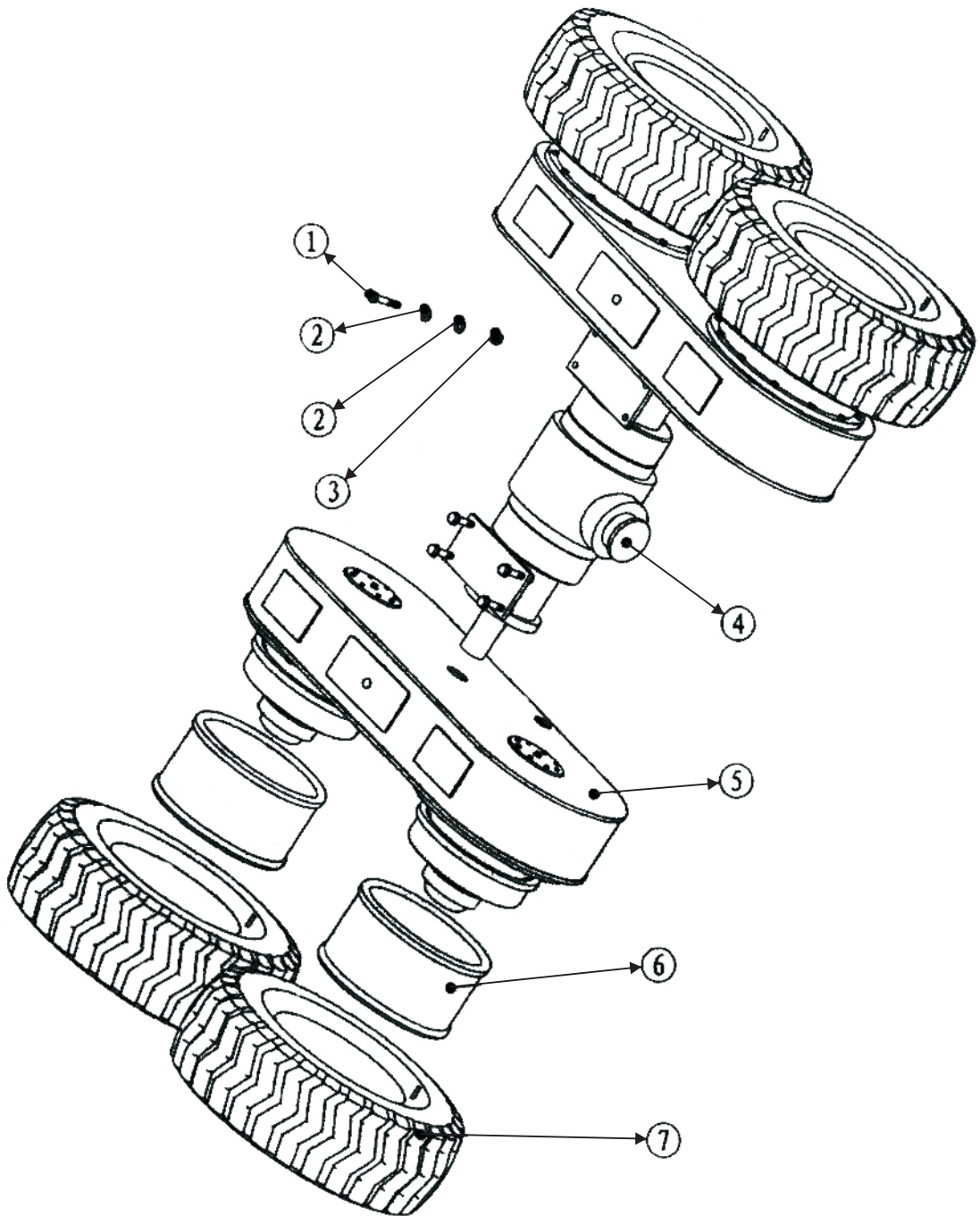

14-2- Núcleo de diferencial 1

CODIGO DOWEL	PIEZA	DESCRIPCION	CANT
MM165.14B.010	5	NUCLEO DIFERENCIAL COMPLETO	1
MM165.14B.011	1	TAPA CARCASA DIFERENCIAL	1
	2	BULON M12x20	3
MM165.14B.013	3	TUERCA SOPORTE DE JAULA	2
MM165.14B.014	4	PLACA TRABA	2
	5		2
MM165.14B.016	6	BULON M10x1x20	4
MM165.14B.017	7	PIN 16X65	1
MM165.14B.018	8	RODAMIENTO 32016	2
	9	BULON M16x35	20
MM165.14B.020	10	JAULA DIFERENCIAL COMPLETA	1
MM165.14B.021	11	CORONA DE DIFERENCIAL	1
MM165.14B.022	12	TAPON ROSCADO	3
	13	BULON M8x25	8
	14	ARANDELA 8	8
MM165.14B.025	15	TAPA DE INSPECCION	1
MM165.14B.026	16	PIN 16X40	1
MM165.14B.027	17	CARCASA DE DIFERENCIAL	1
	18	ARANDELA 12	7
	19	BULON M14x55	7
	20	ARANDELA 14	1
	21	BULON M14x55	1
MM165.14B.032	22	TUERCA DE PIÑON	1
MM165.14B.033	23	RIBETE ENTRADA	1
MM165.14B.034	24	ARO GUARDADPOLVO	1
MM165.14B.035	25	RETEN 75X95X10	2
MM165.14B.036	26	TAPA ENTRADA PIÑON	1
MM165.14B.037	27	JUNTA	1
MM165.14B.038	28	RODAMIENTO 30311	2
MM165.14B.039	29	SOPORTE RODAMMIENTO	1
MM165.14B.040	30	ARANDELA AJUSTE	1set
MM165.14B.041	31	ARANDELA AJUSTE	1set
MM165.14B.042	32	BUJE	1
MM165.14B.043	33	PIÑON DE DIFERENCIAL	1
MM165.14B.044	34	RODAMIENTO NJ307	1

14-2- Núcleo de diferencial 1

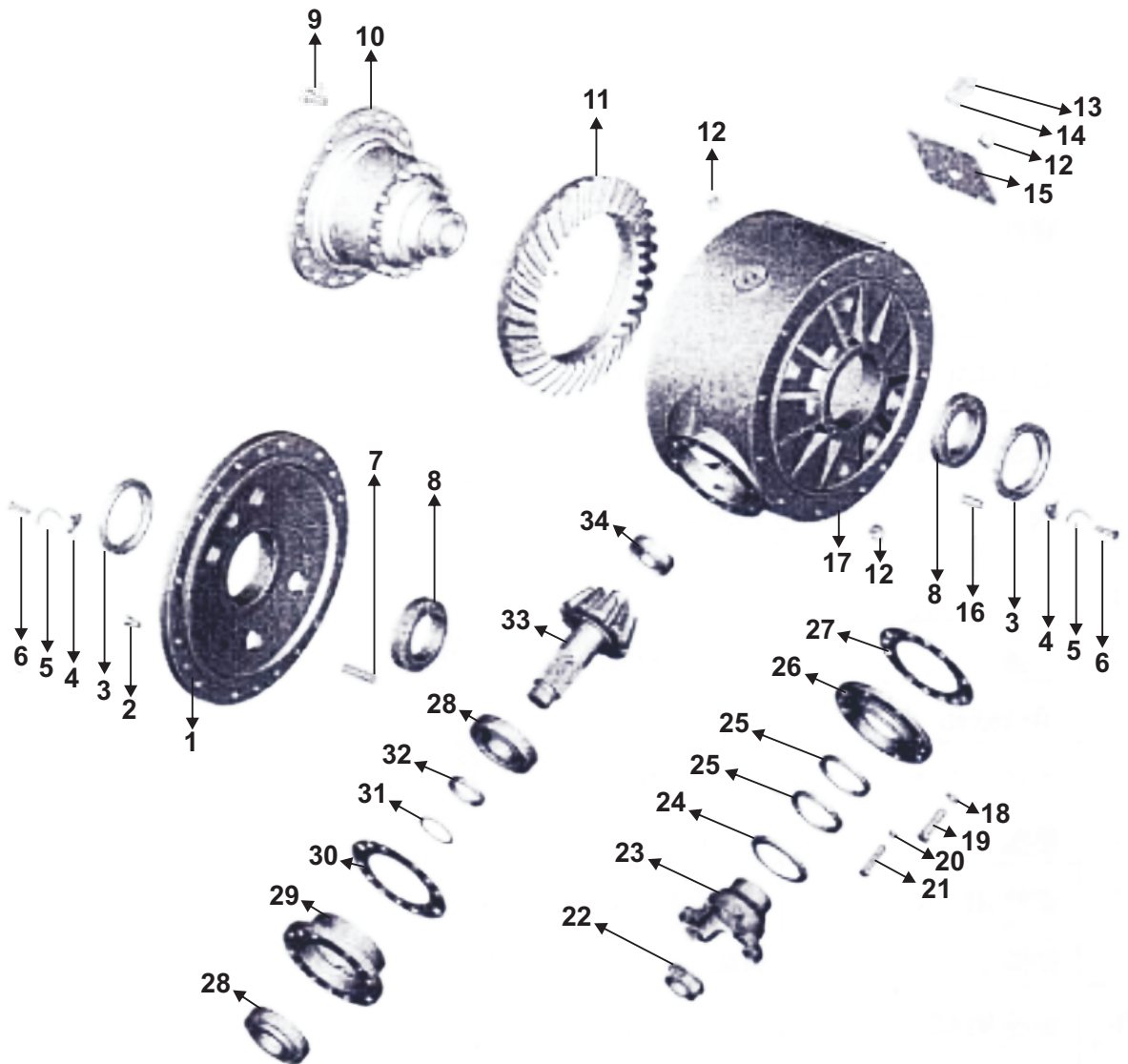

14-3- Núcleo de diferencial 2

CODIGO DOWEL	PIEZA	DESCRIPCION	CANT
MM165.14C.051	1	TAPA CARCASA JAULA DIFERENCIAL	1
MM165.14C.052	2	MANGA ENGRANAJE	2
MM165.14C.053	3	ESPACIADOR	1
MM165.14C.054	4	ASIENTO RESORTE	2
MM165.14C.055	5	RESORTE CONO	2
MM165.14C.056	6	ARO IMPULSOR	2
MM165.14C.057	7	ARO TRABA	2
MM165.14C.058	8	CRUCETA	1
MM165.14C.059	9	ARO AMORTIGUADOR	1
MM165.14C.060	10	ARO CENTRAL	1
MM165.14C.061	11	CARCASA JAULA DIFERENCIAL	1
	12	ARANDELA 12	16
	13	BULON M12X70	16

14-3- Núcleo de diferencial 2

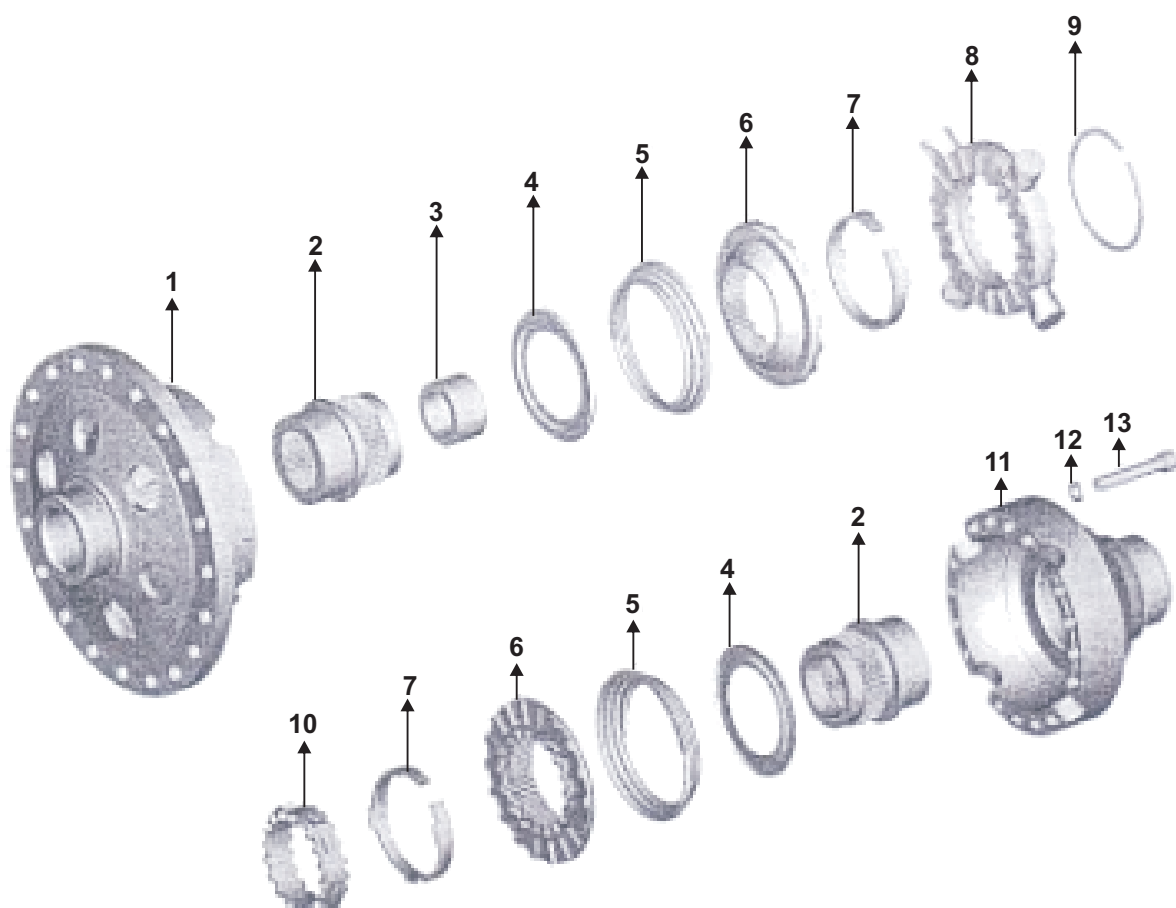

14-4- Reductor del diferencial

CODIGO DOWEL	PIEZA	DESCRIPCION	CANT
MM165.14D.070	2	MANGA REDUCTORA DE DIFER.	2
MM165.14D.071	1	EJE DE MANGA REDUCTORA	2
MM165.14D.072	2	RETEN 165X190X13	2
MM165.14D.073	3	RODAMIENTO 33022	2
MM165.14D.074	4	CARCA SA DE MANGA REDUCTOR	2
MM165.14D.075	5		2
MM165.14D.076	6	RODAMIENTO 32019	2
MM165.14D.077	7	ARO DE ALAMBRE	2
MM165.14D.078	8	SOPORTE DE CORONA	2
MM165.14D.079	9	CORONA DE REDUCTOR	2
MM165.14D.080	10	TUERCA CIRCULAR	4
MM165.14D.081	11	ARANDELA TRABA	2
MM165.14D.082	12	EJE DE REDUCTOR	2
	13	ARO SEEGER Ø48	6
MM165.14D.084	14	TRANSPORTADOR PLANETARIO	2
	15	ARANDELA 14	50
	16	BULON M14x40	50
MM165.14D.087	17	PIN 16X40	4
MM165.14D.088	18	EJE DE ENGR PLANETARIO	6
MM165.14D.089	19		6
MM165.14D.090	20	ARANDELA ESPACIADORA	12
MM165.14D.091	21	ARANDELA RESORTE	18
MM165.14D.092	22	ENGRANAJE PLANETARIO	6
MM165.14D.093	23	AGUJA 6X29.8 (PARA RODAMIENTO)	168

14-4- Reductor del Diferencial

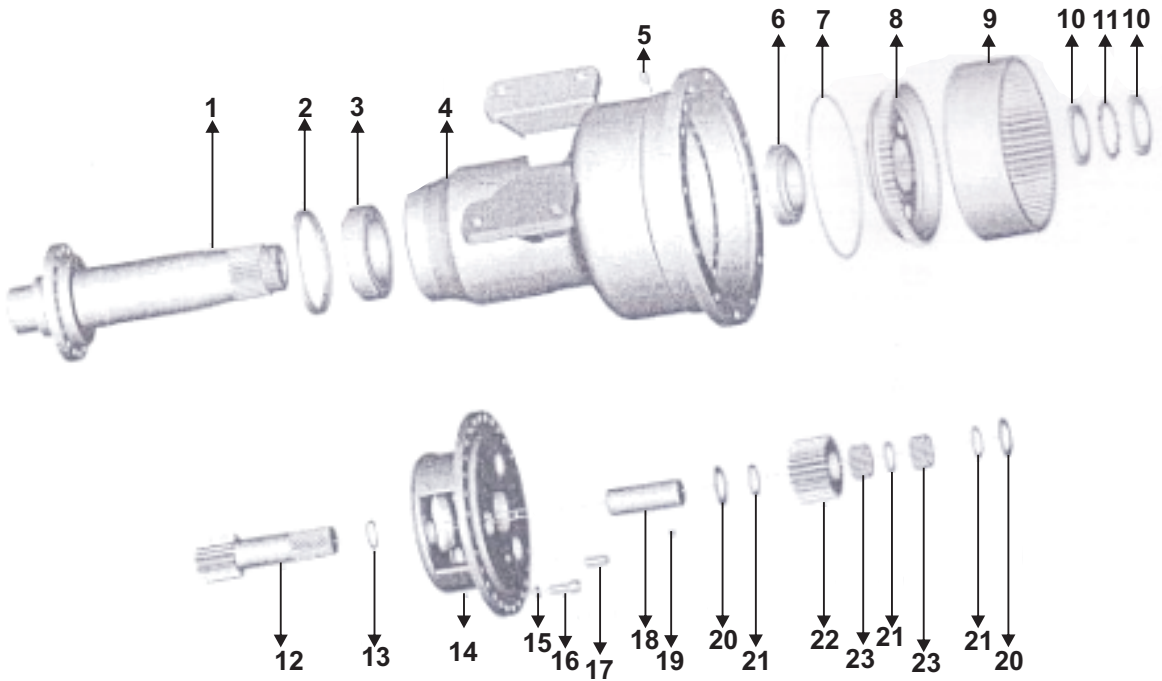

14-5 - Caja Tandem

CODIGO DOWEL	PIEZA	DESCRIPCION	CANT
MM165.14E.107	7	BUJE DE MANGA DIFERENCIAL	2
MM165.14E.109	9	O-RING 250x6	2
MM165.14E.118	18	TAPA DE PALIER	4
MM165.14E.119	19	O-RING 128x5.3	4
MM165.14E.120	20	RODAMIENTO 33113	4
MM165.14E.121	21	PALIER TRASERO	2
MM165.14E.127	27	RODAMIENTO 32018	4
MM165.14E.128	28	JUNTA DE AJUSTE	4sets
MM165.14E.129	29	ASIENTO DE RETEN	4
MM165.14E.130	30	RETEN 90x110x12	4
MM165.14E.131	31	CALIPER DE FRENO	6
MM165.14E.132	32	BULON DE RUEDA	40
MM165.14E.134	34	TUERCA DE RUEDA	40
MM165.14E.137	37	GUARDAPOLVO	4
MM165.14E.138	38	ARANDELA	4
MM165.14E.139	39	ARANDELA	4
MM165.14E.141	41	MASA DE LLANTA	4
MM165.14E.141B	41	DISCO DE FRENO	4
MM165.14E.149	49	TAPA DE CORONA	2
MM165.14E.151	51	CONO DE PALIER	4
MM165.14E.152	52	O-RING 405X5.33	4
MM165.14E.153	53	CADENA	2sets
MM165.14E.154	54	PALIER DELANTERO	2
MM165.14E.155	55	CORONA DOBLE CADENA	2
MM165.14E.156	56	RODAMIENTO 22317C	2
MM165.14E.157	57	GUARDA DE RODAMIENTO	2
MM165.14E.159	59	TAPA DE RODAMIENTO	2

14-5 - Caja Tandem

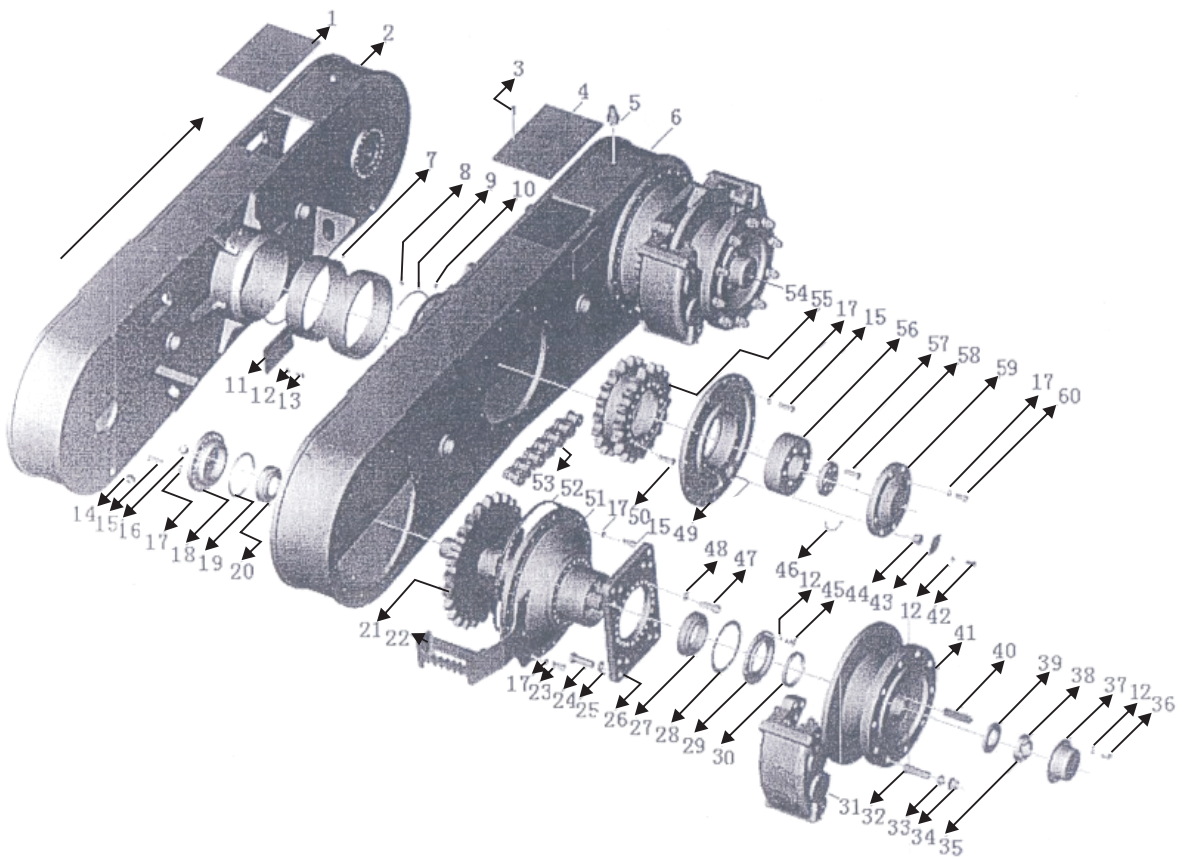

14-6 Caliper de Freno

CODIGO DOWEL	PIEZA	DESCRIPCION	CANT
MM165.14F.171	1	PIN DE CALIPER	4
	2	BULON M10X35	12
	3	TUERCA M10	12
MM165.14F.174	4	CARCASA DE CALIPER	1
	5	ALEMITE	2
MM165.14F.176	6	PISTON DE CALIPER DE FRENO	4
MM165.14F.177	7	ARO SELLO DE PISTON DE FRENO	4
MM165.14F.178	8	GUARDAPOLVO DE CALIPER	4
MM165.14F.179	9	PASTILLA DE FRENO	2
MM165.14F.180	10	O-RING 75x3.1 DE CALIPER	2
MM165.14F.181	11	TAPA DE PISTON CALIPER	1

14-6 Caliper de Freno

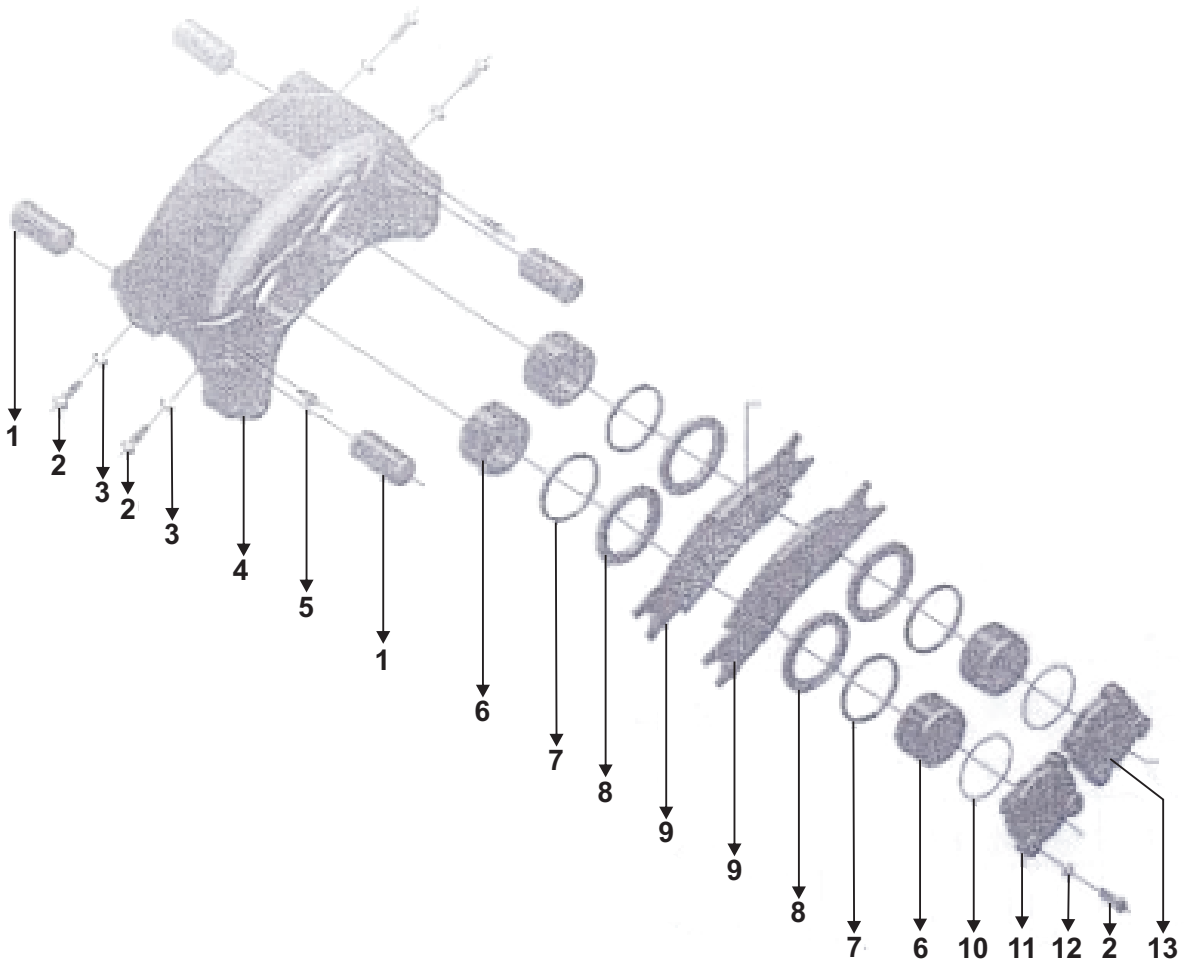

15- Hoja Niveladora y Círculo de Rotación

CODIGO DOWEL	PIEZA	DESCRIPCION	CANT.
MM165.15.001	1	CIRCULO ROTACION HOJA MOTONIV.	1
MM165.15.002	2	CAJA REDUCTORA DE CIRCULO	1
MM165.15.003	3	MONTANTE DE HOJA NIVELADORA	1
MM165.15.004	4	HOJA NIVELADORA COMPLETA	1

15- Hoja Niveladora y Circulo de Rotación

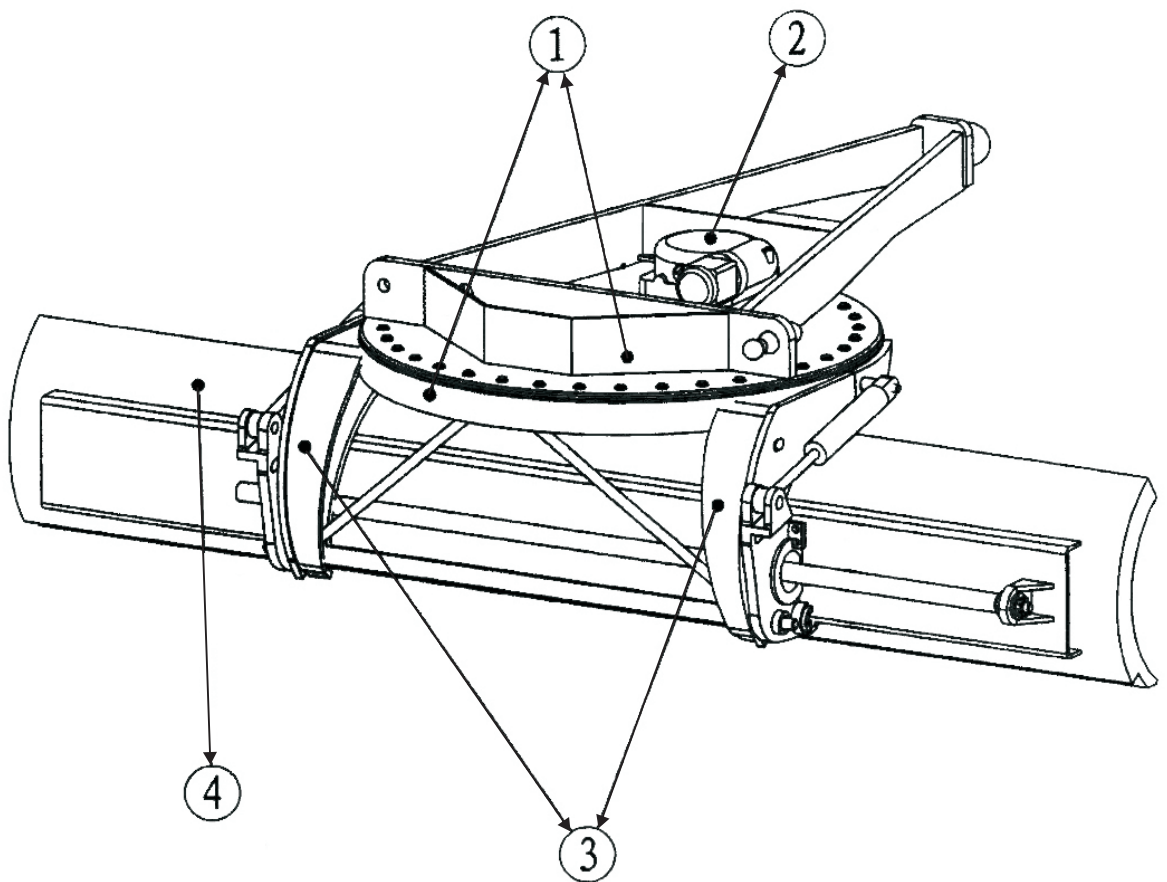

16- Conexión de Caja de Transmisión 1 - MM220

CODIGO DOWEL	PIEZA	DESCRIPCION	CANT.
MM220.16.001	1	CAJA DE TRANSMISION C/CONVERT MM220	1
MM220.16.003	3	JUNTA DE BOMBA	1
MM220.16.004	4	ASIENTO DE BOMBA	1
MM220.16.007	7	JUNTA DE BOMBA	1
MM220.16.010	10	BOMBA HIDRAULICA CKB1020-1008	1
MM220.16.012	12	CONECTOR	2
MM220.16.013	13	ADAPTADOR	2
MM220.16.016	16	CONECTOR	2
MM220.16.019	19	ACOPLE BOMBA HIDRAULICA	1
MM220.16.020	20	SELLO	1
MM220.16.021	21	BOMBA HIDRAULICA GPC3232-C7R	1
MM220.16.022	22	SELLO	1
MM220.16.023	23	ACOPLE BOMBA HIDRAULICA	1
MM220.16.028	28	JUNTA DE BOMBA	1
MM220.16.031	31	SOPORTE CAJA TRANSM DER.	1

16- Conexión de Caja de Transmisión 1 - MM220

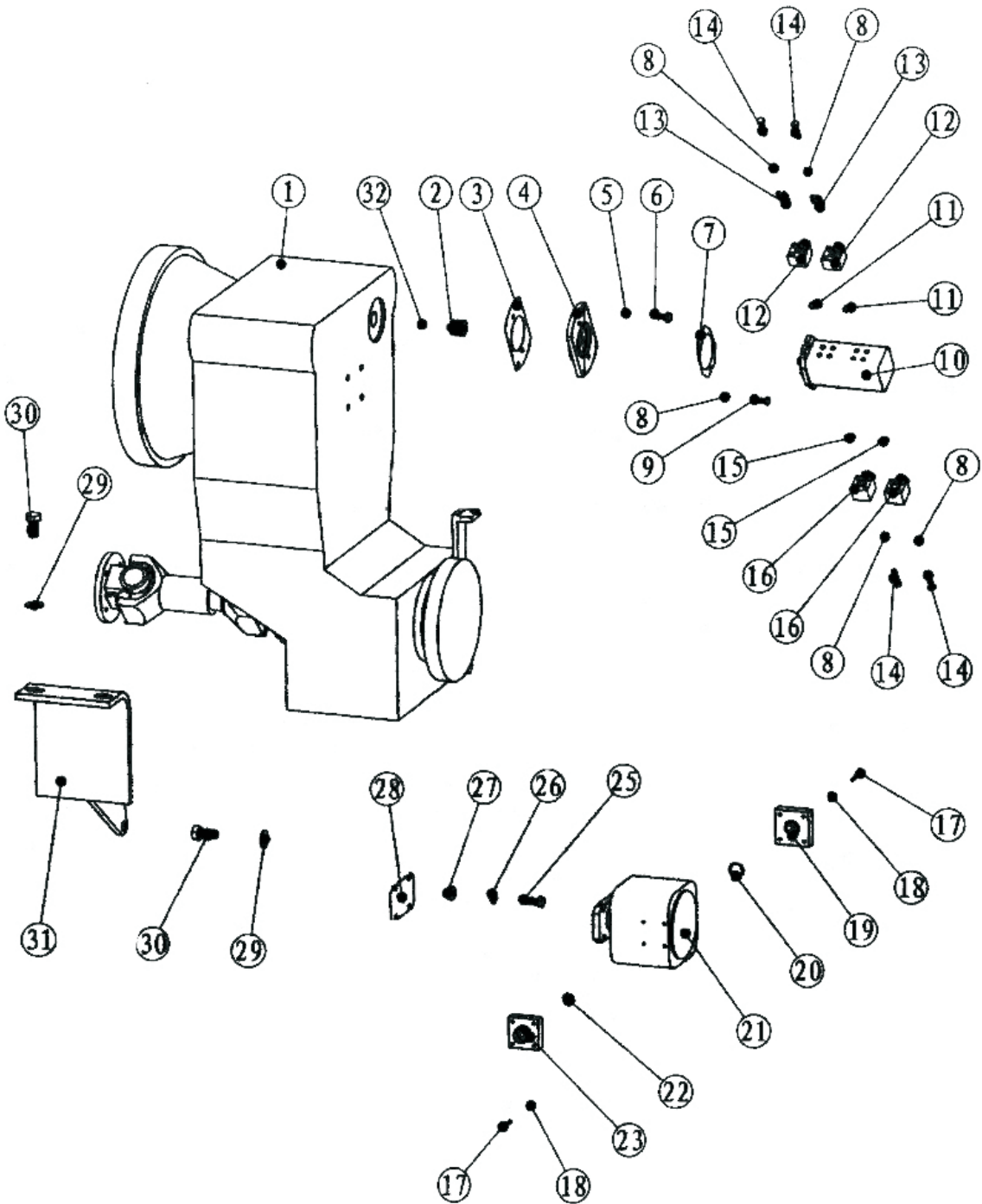

7- Conexión de Caja de Transmisión 2 - MM220

CODIGO DOWEL	PIEZA	DESCRIPCION	CANT.
MM220.17.001	1	BARRA DE MANDO	1
MM220.17.002	2	CONECTOR	1
MM220.17.007	7	SOPORTE CAJA TRANSM DEI ZQ.	1
MM220.17.008	8	ADAPTADOR	1
MM220.17.010	10	PLACA SOPORTE	1

7- Conexión de Caja de Transmisión 2 - MM220

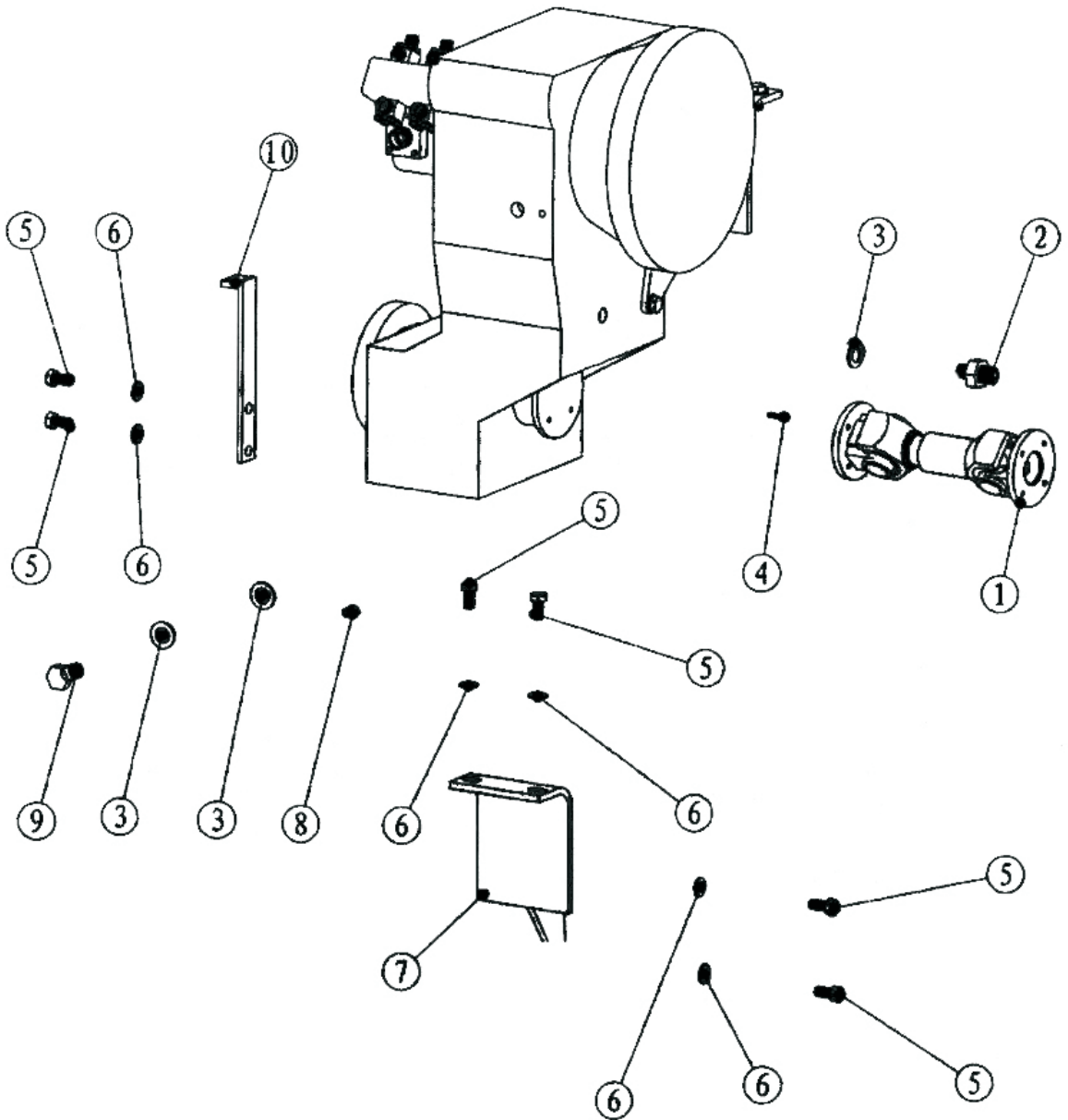

18- Conexión de Caja de Transmisión 1 - MM165

CODIGO DOWEL	PIEZA	DESCRIPCION	CANT.
	1	BULON M20x40	6
	2	ARANDELA 20	6
MM165.18.003	3	SOPORTE CAJA TRANSM IZQ.	1
MM165.18.004	4	ADAPTADOR	4
	5	TORNILLO	1
	6	ARANDELA 30	2
MM165.18.007	7	PLACA SOPORTE DE CAJA TRANSM.	1
	8	BULON M6x50	12
	9	ARANDELA 6	12
MM165.18.010	10	ACOPLE DE BOMBA H. 1	1
MM165.18.011	11	O-RING 56x3.55 DE ACOPLE 1	1
MM165.18.012	12	BOMBA HIDRAULICA	1
MM165.18.013	13	O-RING 28x3.55 DE ACOPLE 2	2
MM165.18.014	14	ACOPLE DE BOMBA H. 2	2
	16	ARANDELA	4
	17	ARANDELA 14	4
	18	BULON M14x40	4
MM165.18.019	19	JUNTA BOMBA HIDR.	4
MM165.18.020	20	PLACA CONECCION	1
	21	BULON M10x40	8
	22	ARANDELA 10	10
MM165.18.023	23	ACOPLE DE BOMBA H. 3	2
MM165.18.024	24	O-RING 22.4x2.65 DE ACOPLE 3	2
MM165.18.025	25	O-RING 18x2.65 DE ACOPLE 4	2
MM165.18.026	26	ACOPLE DE BOMBA H. 4	2
MM165.18.027	27	BOMBA HIDRAULICA	1
MM165.18.028	28	JUNTA BOMBA HIDR.	1
MM165.18.029	29	ASIENTO DE BOMBA	1
MM165.18.030	30	JUNTA ASIENTO DE BOMBA	1
MM165.18.031	31	BUJE ACOPLE	1
	33	ARANDELA 12	2
	34	BULON M12x30	2
	35	BULON M10x30	2

18- Conexión de Caja de Transmisión 1 - MM165

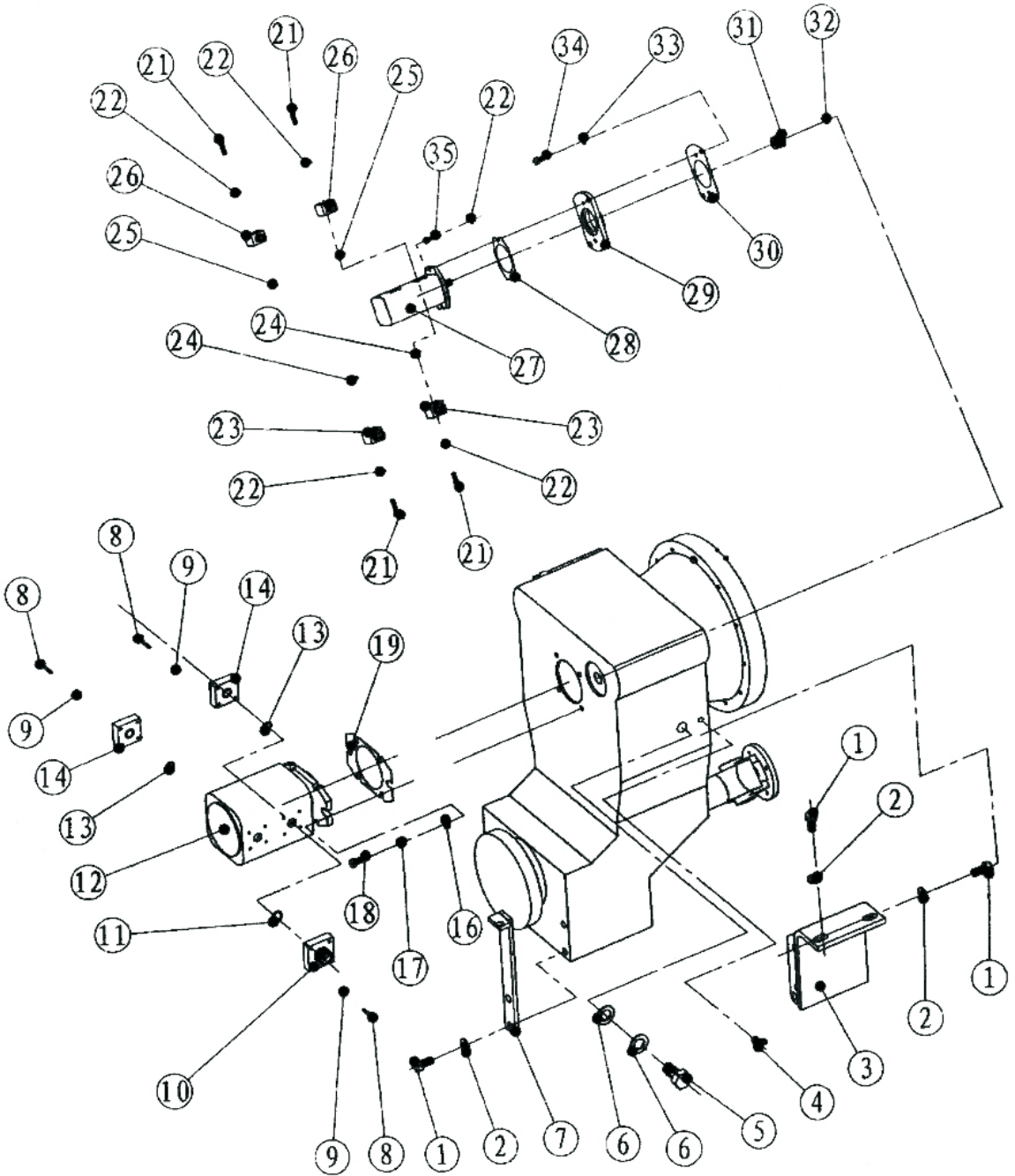

21- Conexión de Caja de Transmisión 2 - MM165

CODIGO DOWEL	PIEZA	DESCRIPCION	CANT.
	1	BULON M20x40	4
	2	ARANDELA 20	4
MM165.21.003	3	CAJA DE TRANSMICION C/CONVERTIDOR	1
MM165.21.004	4	SOPORTE CAJA TRANSM DER.	1
MM165.21.005	5	BULON	1
MM165.21.006	6	BARRA MANDO	1
	7	ARANDELA 30	1
MM165.21.008	8	ACOPLE	1
	9	BULON M10x35	4
	10	BULON M10x75	12

21- Conexión de Caja de Transmisión 2 - MM165

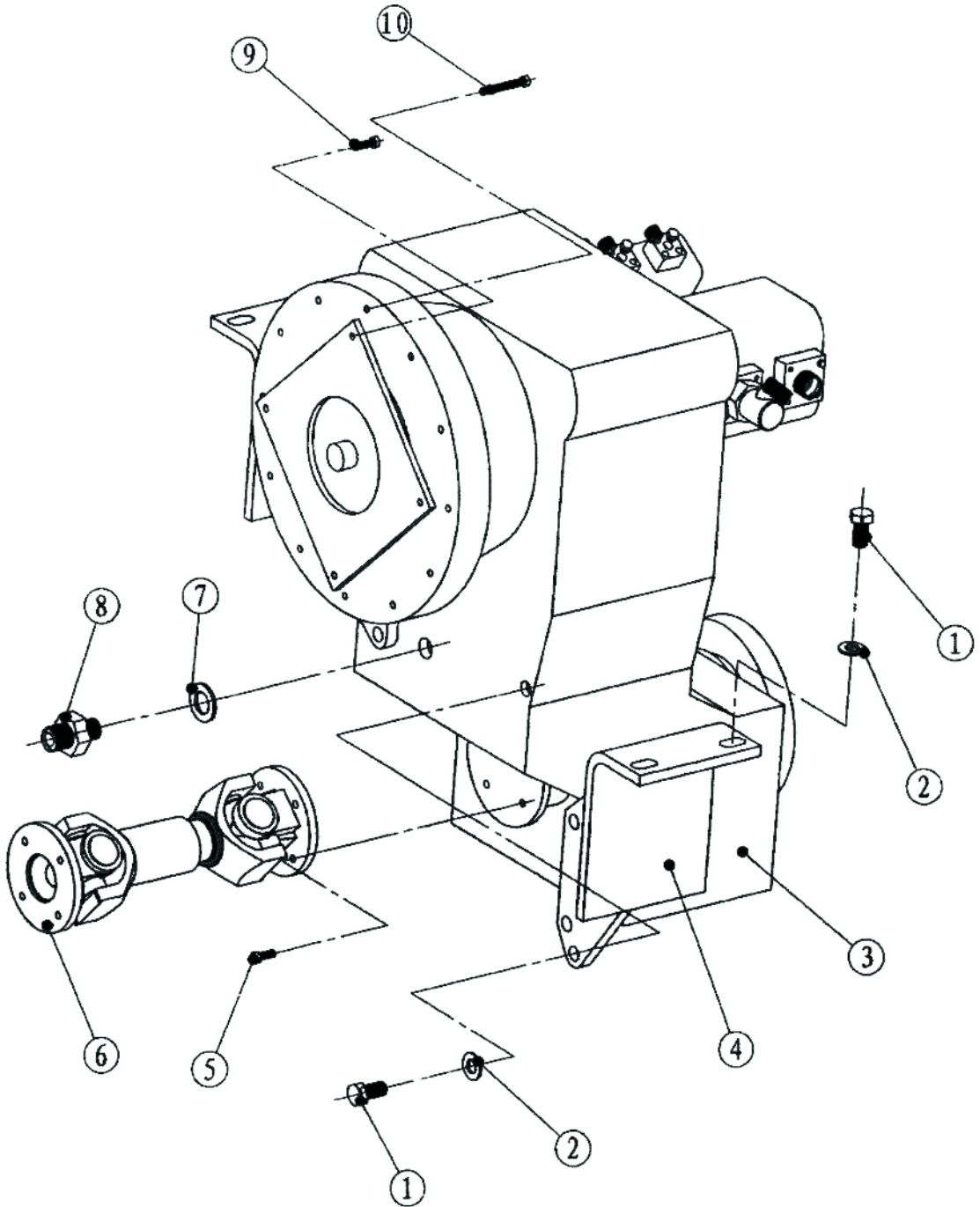

22- Capó 1

CODIGO DOWEL	PIEZA	DESCRIPCION	CANT.
MM165.22.001	1	CAPÓ	1
MM165.22.002	2	BUJE GRANDE DE CAPÓ	2
MM165.22.003	3	BUJE PEQUEÑO DE CAPÓ	2
MM165.22.004	4	ARANDELA ESPACIADORA	2
	5	ARANDELA	2
	6	BULON M12x30	2
MM165.22.007	7	SOPORTE DE CILINDRO CAPÓ	2
	8	ARANDELA 8	4
	9	BULON M8x20	4
MM165.22.010	10	CILINDRO NEUMATICO CAPÓ	2

22- Capó 1

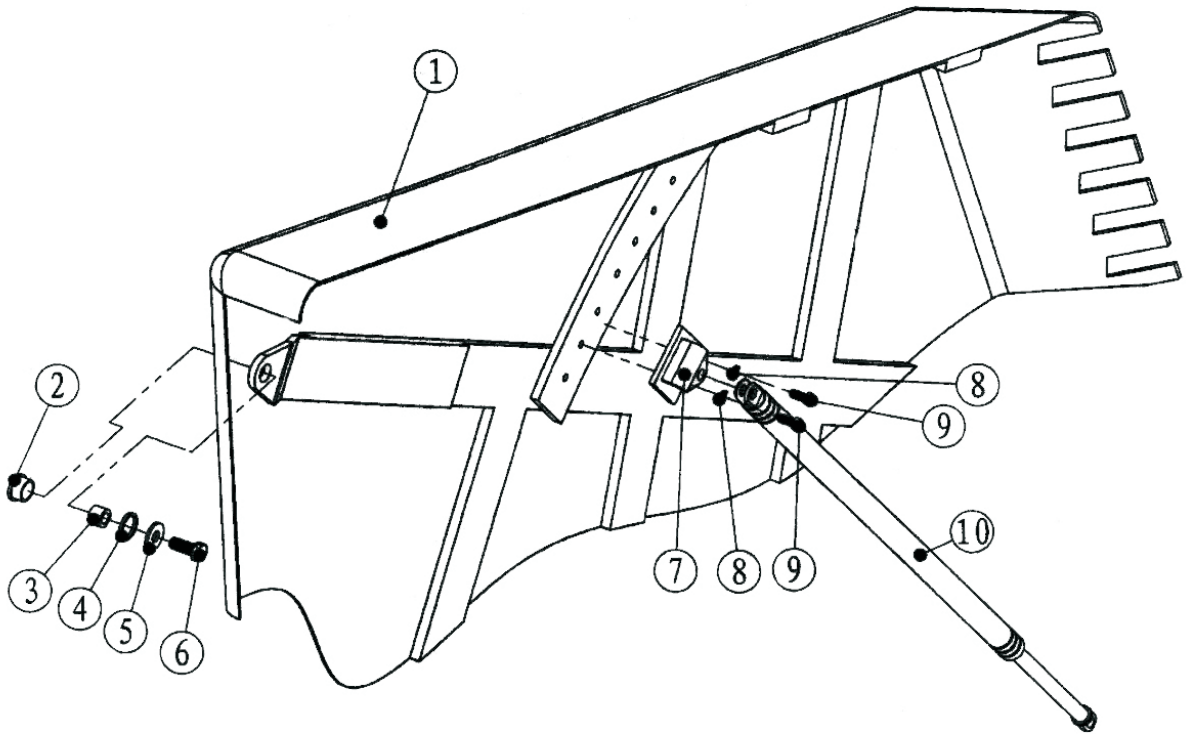

23- Capó 2

CODIGO DOWEL	PIEZA	DESCRIPCION	CANT.
MM165.22.001	1	CAPÓ	1
MM165.23.002	2	MANIJA DE CAPÓ	1
	3	TUERCA M6	4
MM165.23.004	4	CERRADURA DE CAPÓ	1
	5	ARANDELA 6	3
	6	TORNILLO M6x30	3
	7	TORNILLO M6x40	4
	8	BULON M10x30	2
	9	ARANDELA 10	2
	11	ARANDELA 10	2

23- Capó 2

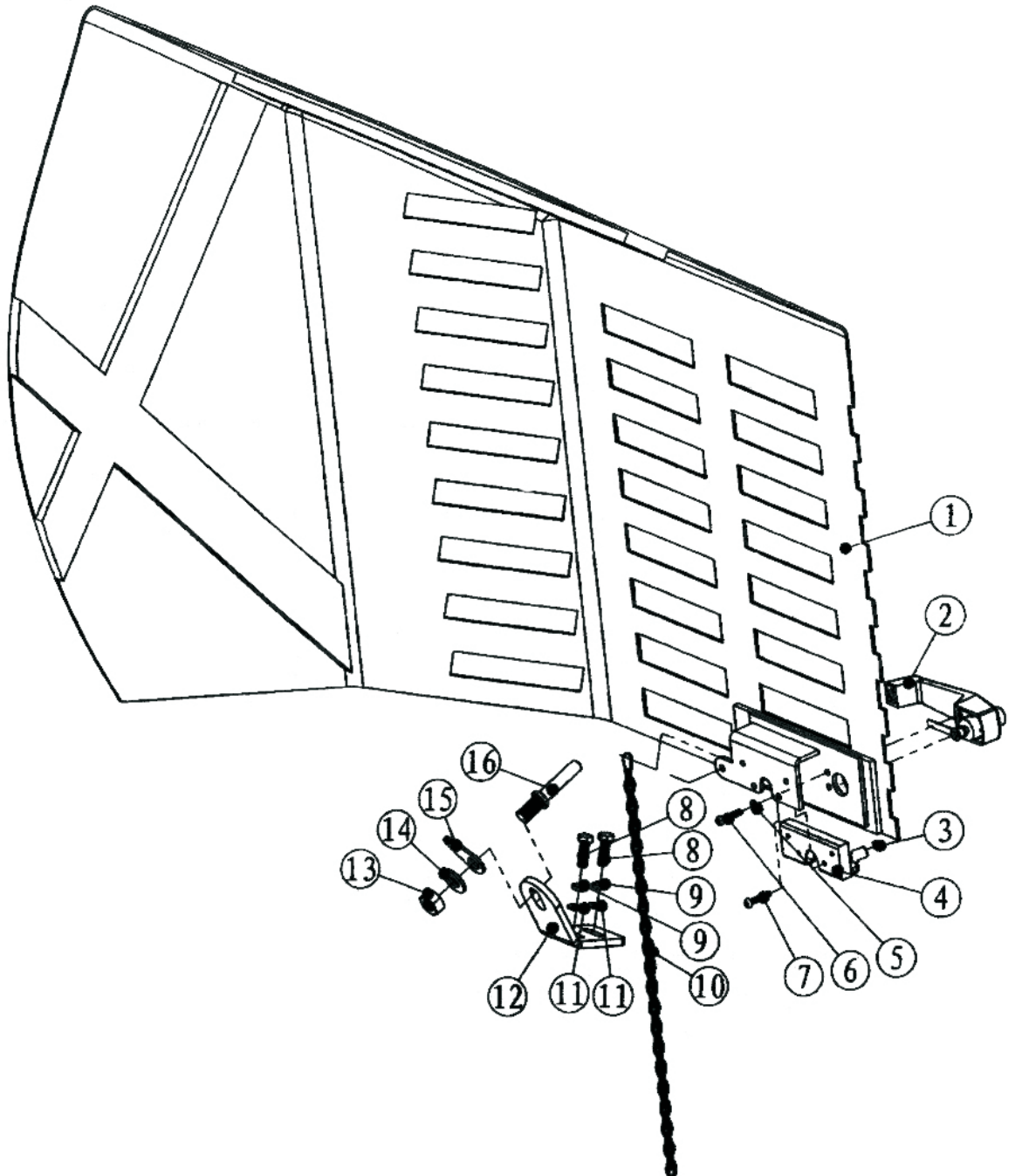

24- Plataforma de Cabina 1

CODIGO DOWEL	PIEZA	DESCRIPCION	CANT.
MM165.24.001	1	BUTACA DE CONDUCTOR	1
	2	TUERCA M8	5
	3	BULON M8x20	5
	4	BULON M4x10	2
	5	ARANDELA 4	2
MM165.24.008	8	CAJA DE HERRAMIENTAS	1
	10	BULON M4x12	2
MM165.24.011	11	FUNDA DE PEDAL	2
MM165.24.012	12	BASE DE CABINA	1
MM165.24.013	13	BRAZO CALCE CABINA	4
	15	ARANDELA 16	8
	16	BULON M16x40	2
	17	TUERCA M10	8
	18	ARANDELA 10	4
	19	BULON M10x25	4
MM165.24.020	20	ALFOMBRA DE CABINA	1
	23	ARANDELA 6	8
	24	BULON M6x16	8
MM165.24.025	25	COVERTOR PLAST. COMANDOS	1
	26	BULON M16x30	6
	27	BULON M12x25	2
	28	ARANDELA 12	2
	29	ARANDELA 4	2
	30	TUERCA M4	2

24- Plataforma de Cabina 1

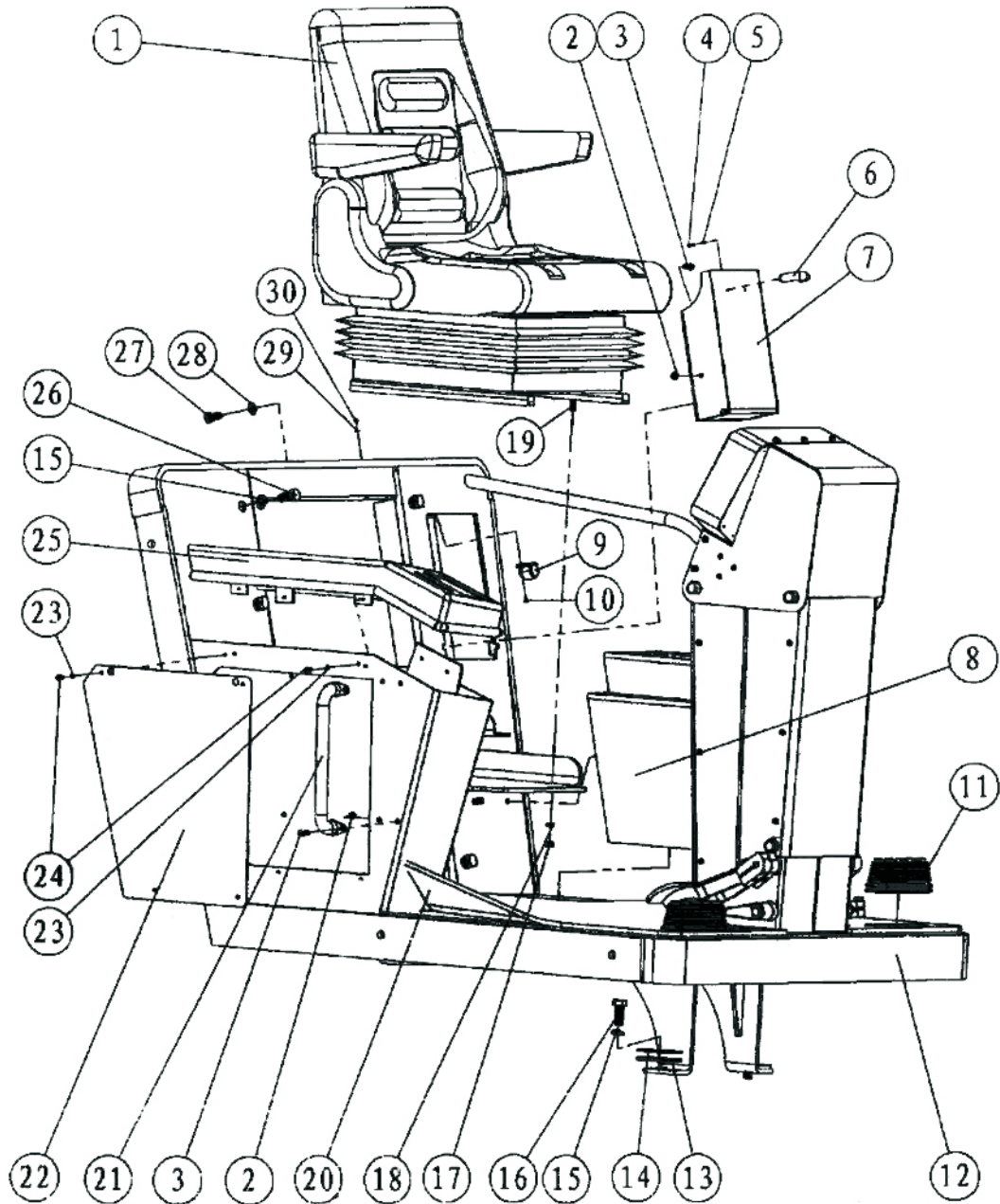

25- Plataforma de Cabina 2

CODIGO DOWEL	PIEZA	DESCRIPCION	CANT.
MM165.25.001	1	SOPORTE DE BUTACA	1
	2	BULON M10x25	4
	3	ARANDELA 10	4
	4	BULON	1
MM165.25.006	6	TAPA	1
MM165.25.010	10	PLACA BASE TABLERO	1
MM165.25.011	11	PIN	2
MM165.25.012	12	BARRA DE PEDAL	1
MM165.25.015	15	PLACA BASE TABL. IZQ.	2
	16	BULON M6x16	12
	17	ARANDELA 6	12
MM165.25.018	18	TAPA DE GOMA	8
	19	BULON M10x35	8
	20	ARANDELA 10	4
MM165.25.021	21	ASIENTO DE NYLON	8
MM165.25.022	22	PLACA TRAS. BASE TABLERO	1
MM165.25.023	23	PIN	1
MM165.25.024	24	CILINDRO NEUMAT DE CABINA	1
MM165.25.025	25	CACASA TRAS. TABLERO	1
	26	BULON M6x16	7
	27	ARANDELA 6	7
MM165.25.028	28	TABLERO DE INSTRUMENTOS	1
MM165.25.030	30	PLACA BASE TABL DER.	2

25- Plataforma de Cabina 2

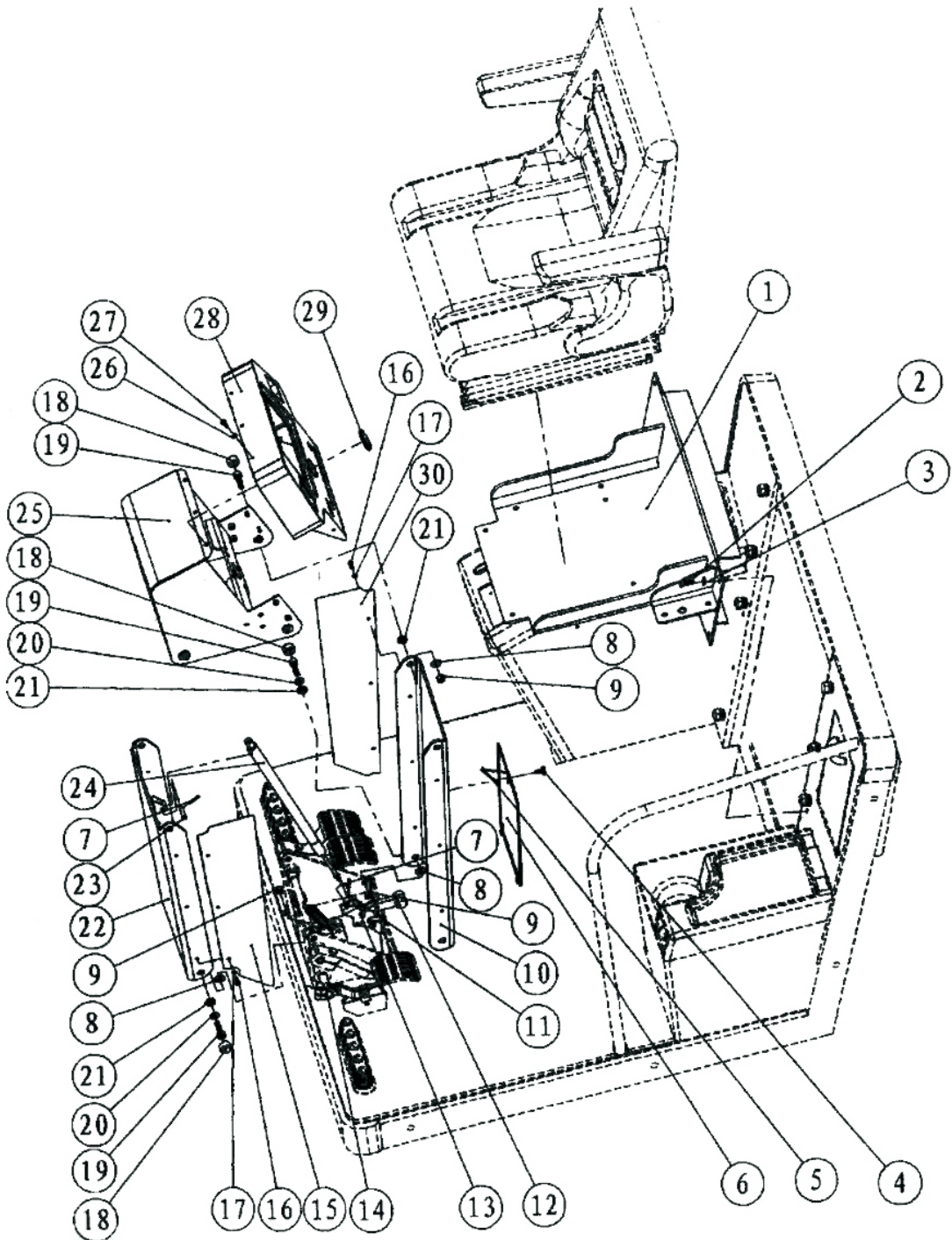

27- Palanca de Freno de Mano

CODIGO DOWEL	PIEZA	DESCRIPCION	CANT.
MM165.27.001	1	PALANCA FRENO MANO	1
MM165.27.005	5	CABLE FRENO MANO	1

27- Palanca de Freno de Mano

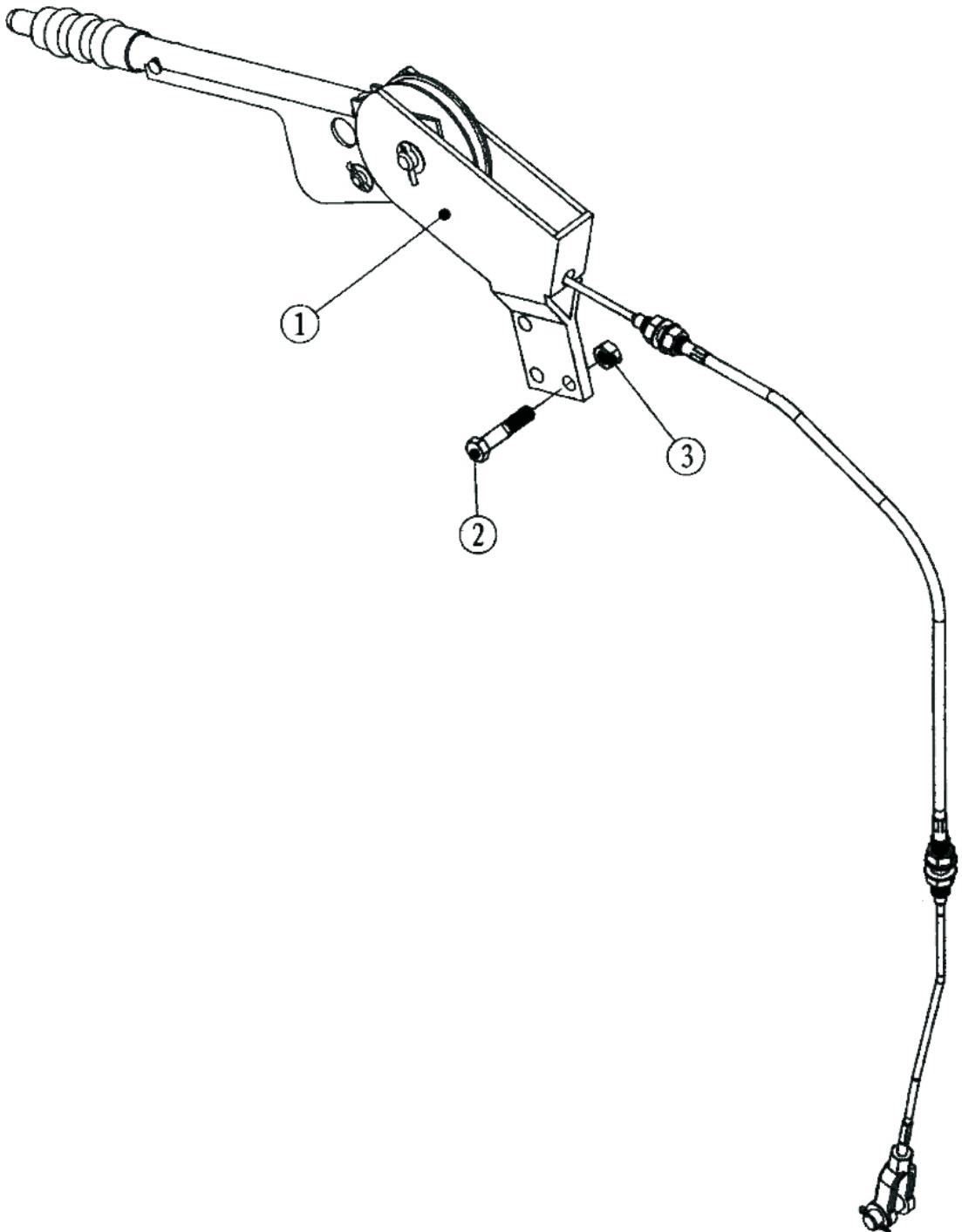

28- Control de Freno 1

CODIGO DOWEL	PIEZA	DESCRIPCION	CANT.
MM165.28.001	1	PEDAL C/ VALVULA DE FRENO	1
MM165.28.002	2	ACOPLE VALV. DE FRENO	3
MM165.28.003	3	ACOPLE VALV. DE FRENO	2
MM165.28.004	4	MANGUERA AC. HIDR	2
MM165.28.005	5	CONECTOR "T"	1
MM165.28.006	6	MANGUERA AC. HIDR	1
MM165.28.007	7	PERNO HUECO	4
MM165.28.008	8	ARANDELA COMBINADA	4
MM165.28.009	9	MANGUERA AC. HIDR	4
MM165.28.010	10	CONECTOR "T"	2
MM165.28.011	11	ACOPLE DE MANGUERA	2
MM165.28.012	12	CONECTOR "T"	2
MM165.28.013	13	MANGUERA AC. HIDR	1
MM165.28.014	14	VALVULA DE PRESION	1
	15	ARANDELA 6	2
	16	BULON M6x22	2
MM165.28.017	17	ACOPLE DE MANGUERA	1
MM165.28.018	18	MANGUERA AC. HIDR	1
MM165.28.019	19	MANGUERA AC. HIDR	1
MM165.28.020	20	ACOPLE DE MANGUERA	1
	21	ARANDELA COMBINADA	1

28- Control de Freno 1

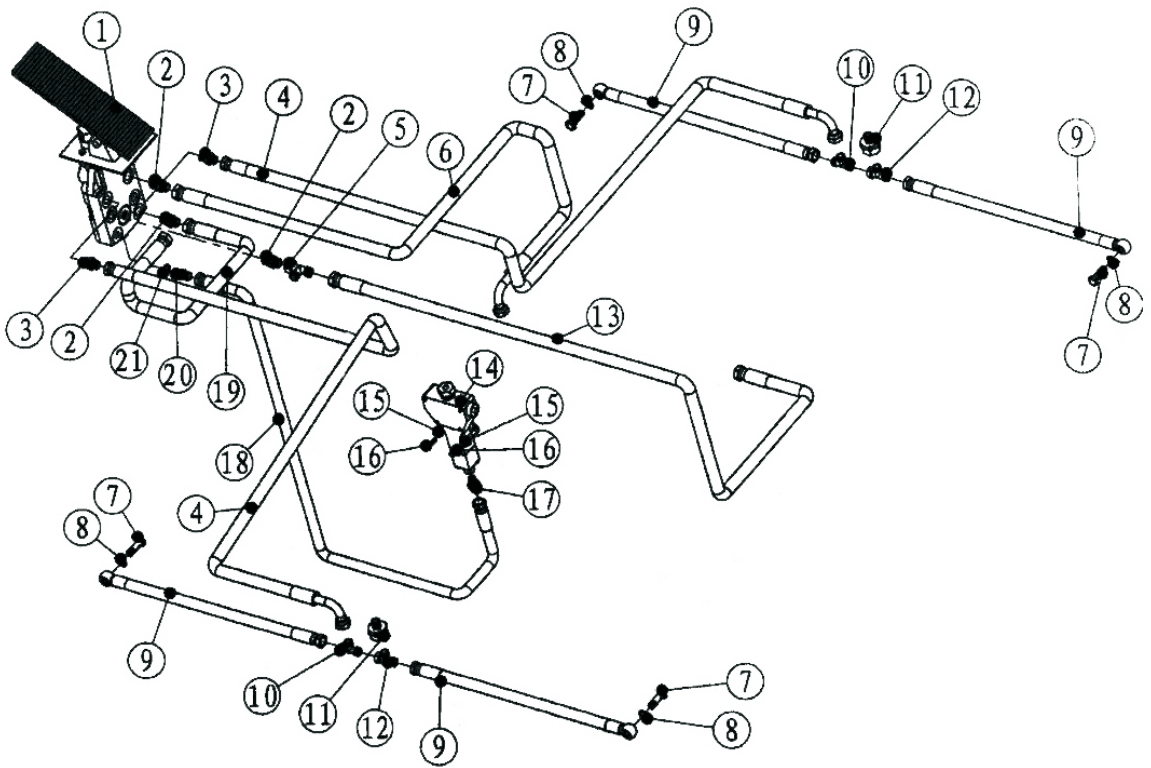

29- Control de Freno 2

CODIGO DOWEL	PIEZA	DESCRIPCION	CANT.
MM165.29.001	1	CONECTOR "T"	3
MM165.29.002	2	MANGUERA AC. HIDR.	1
MM165.29.003	3	ACOPLE D MANGUERA	1
MM165.29.004	4	CODO A COPLE	1
MM165.29.005	5	MANGUERA AC. HIDR.	1
MM165.29.006	6	ACUMULADOR	1
MM165.29.007	7	ADAPTADOR DE ACUMULADOR	1
	8	TUERCA DE ADAPTADOR	1
MM165.29.009	9	ACOPLE DE MANGUERA	1
MM165.29.010	10	MANGUERA AC. HIDR.	1
MM165.29.011	11	CODO A COPLE	1
MM165.29.012	12	ADAPTADOR DE CODO	1
MM165.29.013	13	ADAPTADOR DE CODO	2
	14	ARANDELA COMBINADA	1
MM165.29.015	15	VALVULA LIMIT. PRESION	5
MM165.29.016	16	MANGUERA AC. HIDR.	1

29- Control de Freno 2

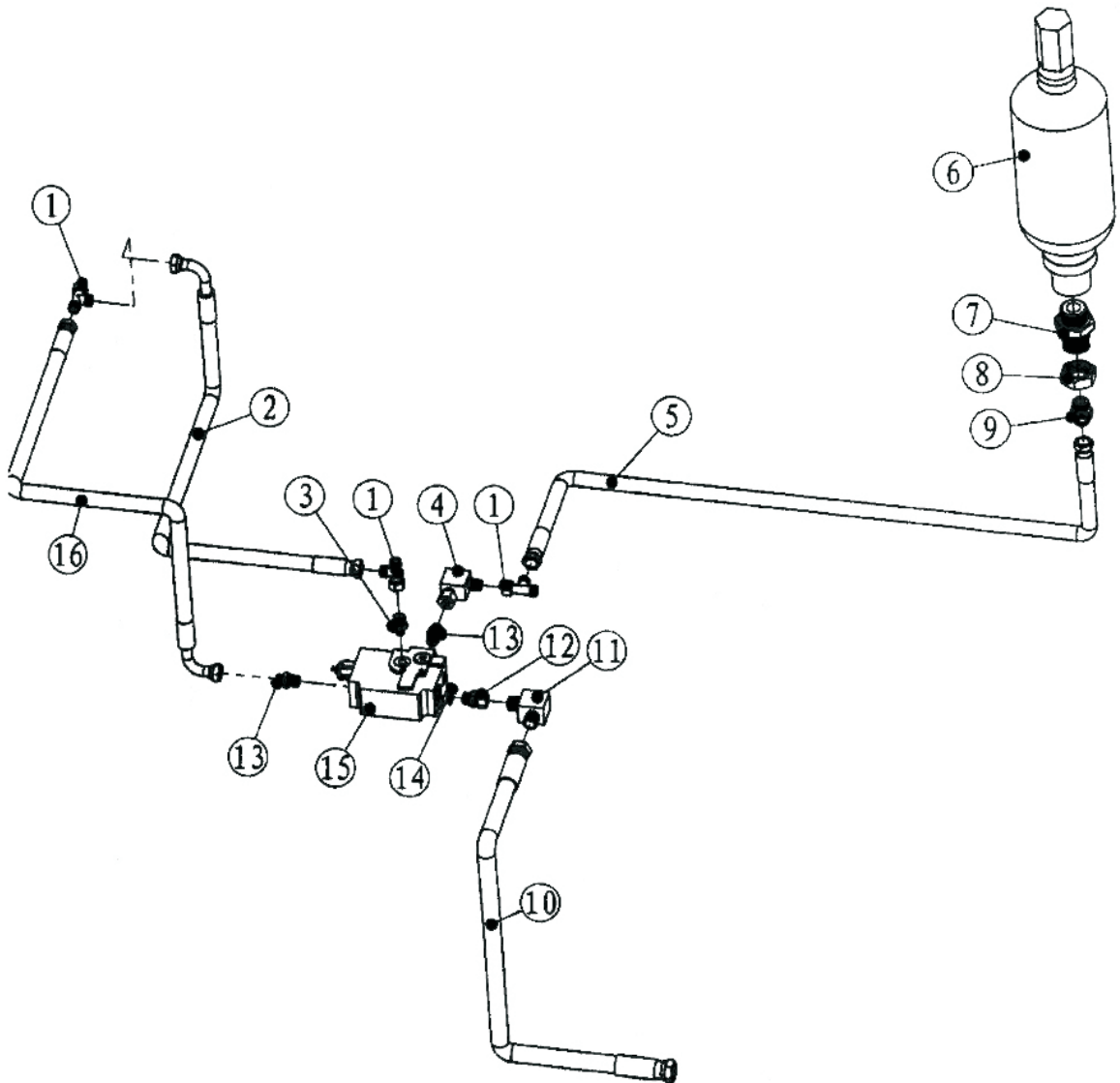

30- Comandos de Control 1

CODIGO DOWEL	PIEZA	DESCRIPCION	CANT.
MM165.30.001	1	BRAZO SOPORTE ROTACION	10
	2	TUERCA 10	20
	3	ARANDELA	10
MM165.30.004	4	ARANDELA DE NYLON	30
	5	PIN	10
MM165.30.006	6	BUJE DE BRAZO	30
MM165.30.007	7	EJE DE BRAZO ROTAC.	20
MM165.30.008	8	PLACA	10

30- Comandos de Control 1

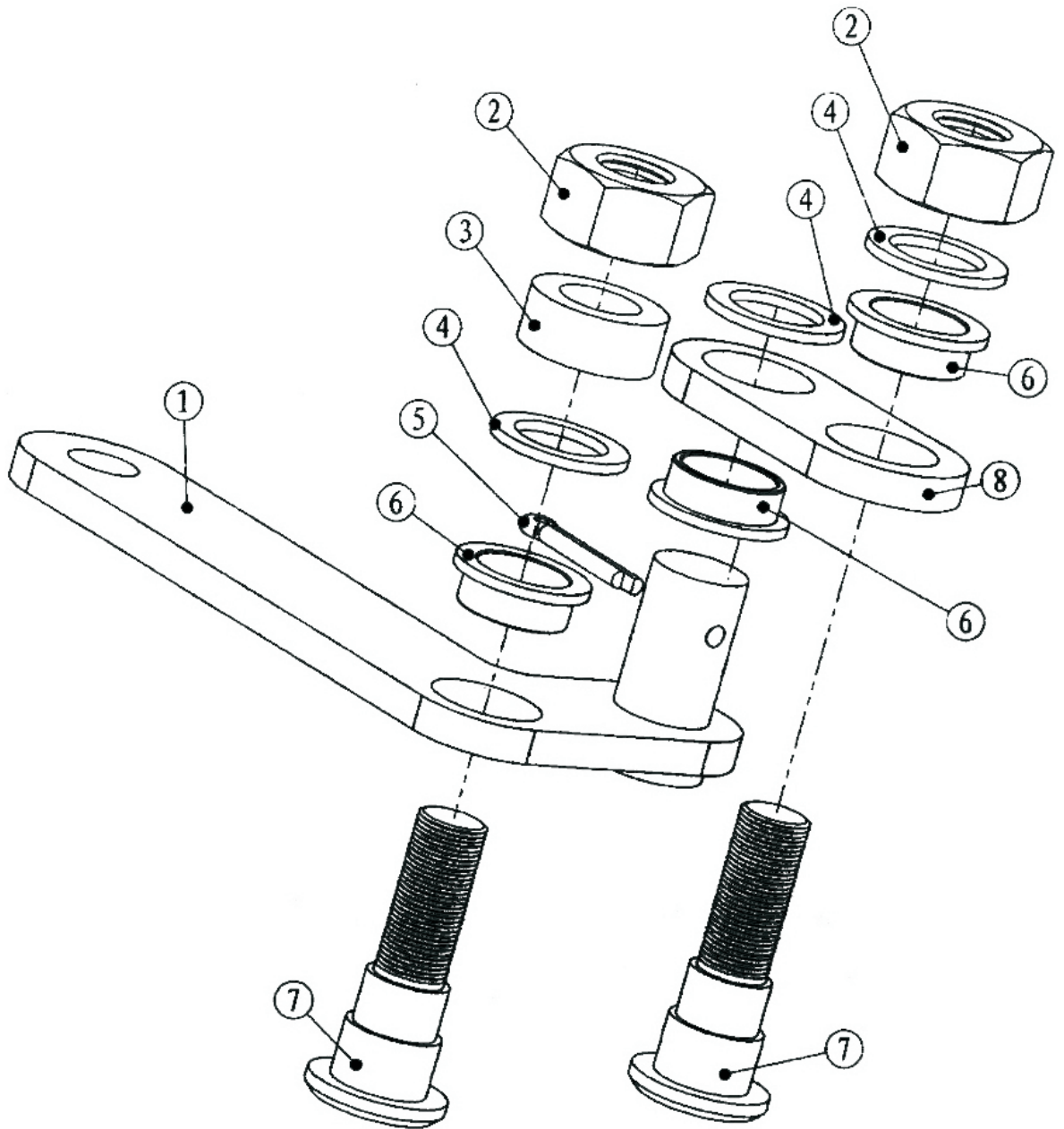

31- Comandos de Control 2

CODIGO DOWEL	PIEZA	DESCRIPCION	CANT.
	1	TUERCA M8	3
	2	ARANDELA 8	3
	3	BULON M8x20	3
MM165.31.004	4	EJE DE PALANCAS	2
MM165.31.005	5	PERILLA DE PALANCA	10
MM165.31.006	6	PALANCA COMANDO	4
MM165.31.007	7		6
MM165.31.008	8	BUJE DE PALANCA	20
MM165.31.009	9	ARANDELA RETENCION	2
	10	ARANDELA 10	2
	11	BULON M10x16	2
	12	TUERCA 10	20
	13	BULON M8x30	20
MM165.31.014	14	EXTREMO DE BARRA	20
MM165.31.015	15	BARRA DE PALANCA COMANDO	10
MM165.31.016	16	BRAZO SOPORTE ROTACION	10

31- Comandos de Control 2

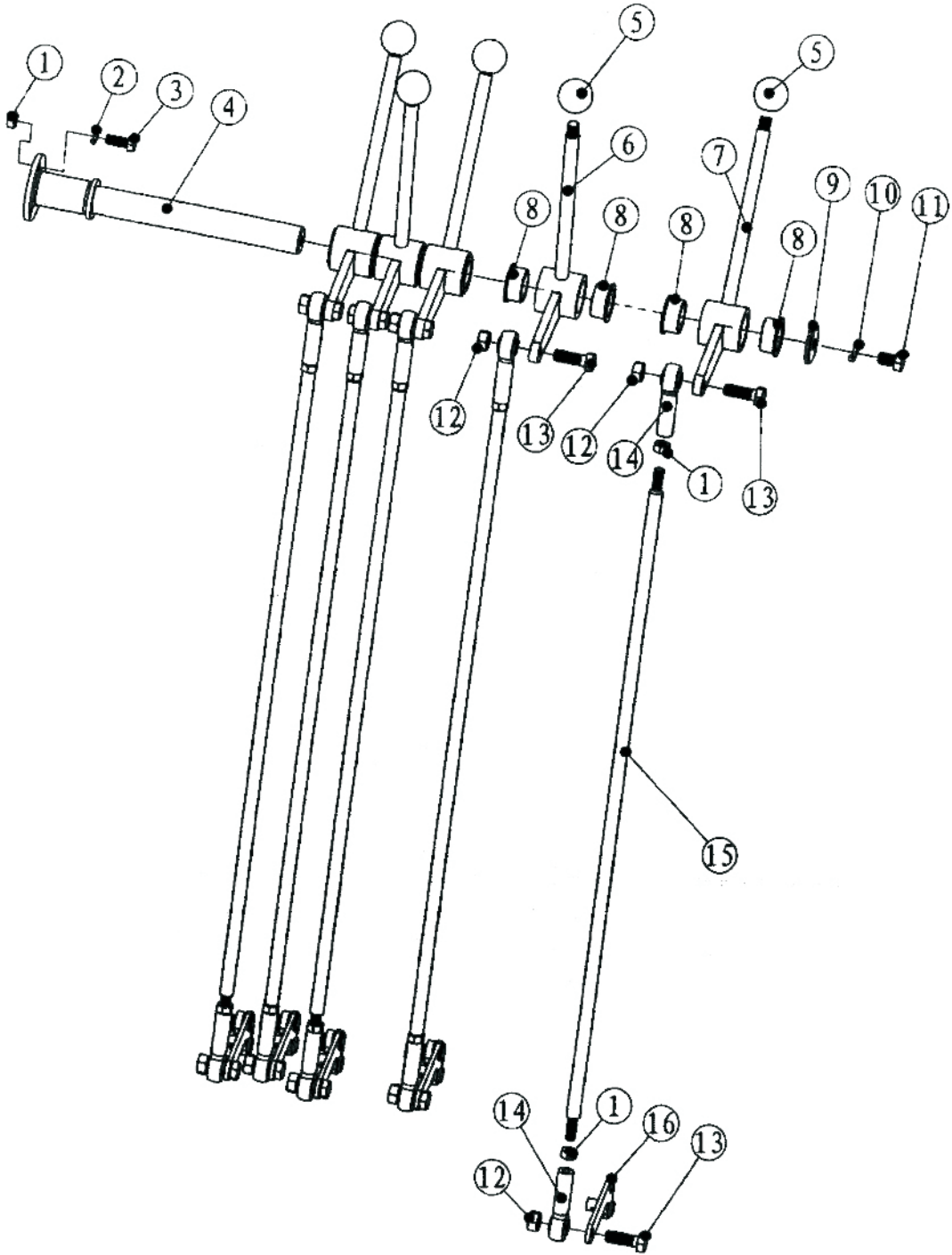

32- Comandos de Control 3

CODIGO DOWEL	PIEZA	DESCRIPCION	CANT.
MM165.32.001	1	PEDAL ACELERADOR COMP	1
	2	BULON M10x30	3
	3	TUERCA M10	3
MM165.32.004	4	SELECTOR DE MARCHAS	1
	5	ARANDELA 8	2
	6	BULON M8x20	2
	7	BULON M6x40	4
	8	ARANDELA 6	4
	9	TUERCA M6	4
MM165.32.010	10	ACELERADOR DE MANO	1
MM165.32.011	11	CABLE ACELERADOR	1

32- Comandos de Control 3

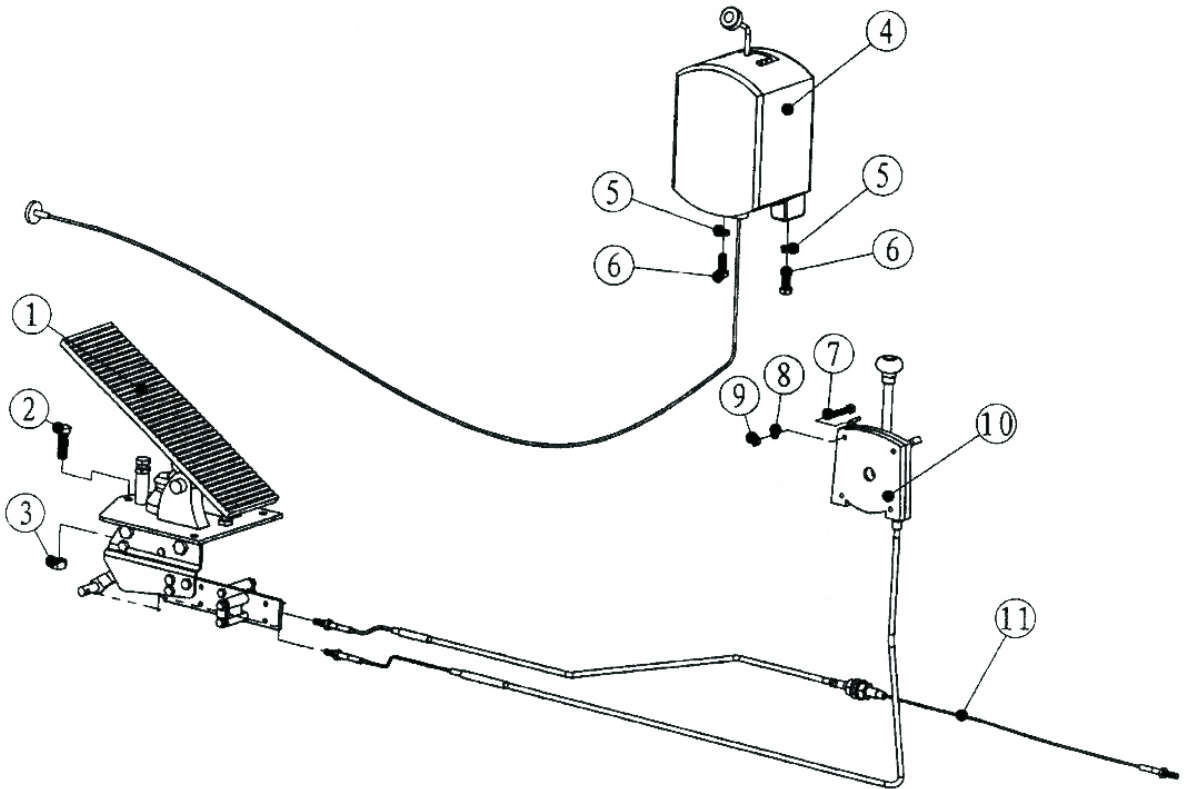

33- Sistema Hidráulico de Trabajo 1

CODIGO DOWEL	PIEZA	DESCRIPCION	CANT.
MM165.33.001	1	MOTOR HIDRAULICO	1
MM165.33.002	2	TANQUE DE ACEITE HIDRAULICO	1
MM165.33.003	3	VALVULA MULTIVIA	1
MM165.33.004	4	ACOPLE	2
MM165.33.005	5	CODO	2
MM165.33.006	6	ACOPLE DE MANGUERA	1
MM165.33.007	7	MANGUERA AC. HIDR	1
MM165.33.008	8	ACOPLE DE MANGUERA	1
MM165.33.009	9	O-RING 19x2.46	2
MM165.33.010	10	ACOPLE	1
	11	MANGUERA AC. HIDR	1
MM165.33.012	12	ACOPLE "T" CC-22	1
	13	MANGUERA AC. HIDR	1
MM165.33.014	14	O-RING 69x2.65	1
	15	ARANDELA 10	2
	16	BULON M10x30	2
MM165.33.017	17	ABRZADERA MANGERA, ASIENTO	1
MM165.33.018	18	ABRZADERA MANGERA, TAPA	1
	19	TUERCA M8	2

33- Sistema Hidráulico de Trabajo 1

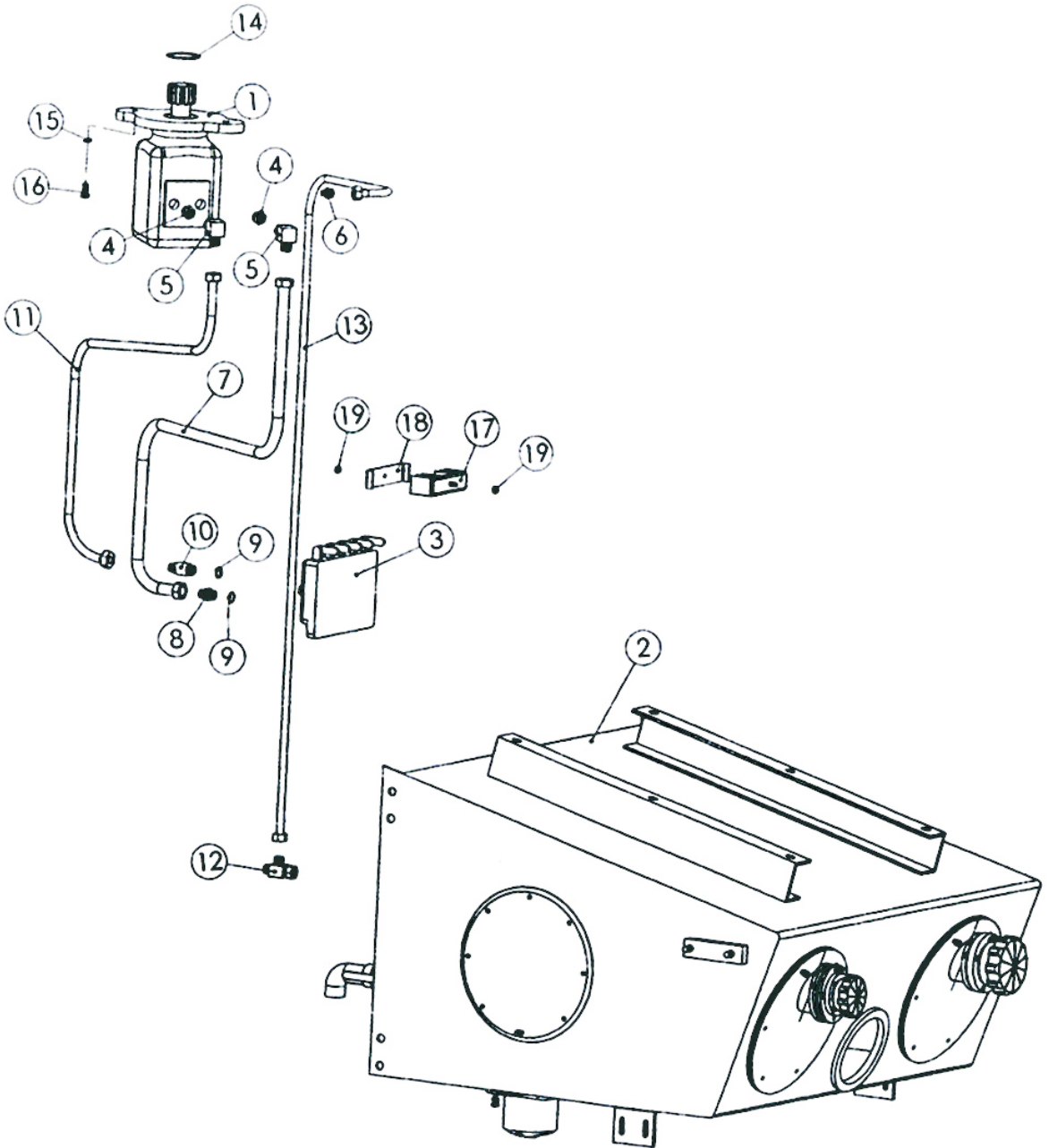

34- Sistema Hidráulico de Trabajo 2

CODIGO DOWEL	PIEZA	DESCRIPCION	CANT.
MM165.34.001	1	CILINDRO POSICIONADOR	1
MM165.34.002	2	CONECTOR	2
MM165.34.003	3	ARANDELA JUNTA	2
MM165.34.004	4	VALVULA MULTIVIA	1
MM165.34.005	5	CONECTOR	1
MM165.33.008	6	CONECTOR	1
MM165.33.005	7	CODO CONECTOR	1
MM165.34.008	8	MANGUERA A.C. HIDR	1
MM165.34.009	9	MANGUERA A.C. HIDR	1
MM165.33.009	10	O-RING 19x2.46	2
	11	BULON M12x45	4
	12	ARANDELA 12	4
	13	ARANDELA 12	4
MM165.33.017	14	ABRZADERA MANGERA, ASIENTO	1
MM165.33.018	15	ABRZADERA MANGERA, TAPA	1
	16	TUERCA M8	2

34- Sistema Hidráulico de Trabajo 2

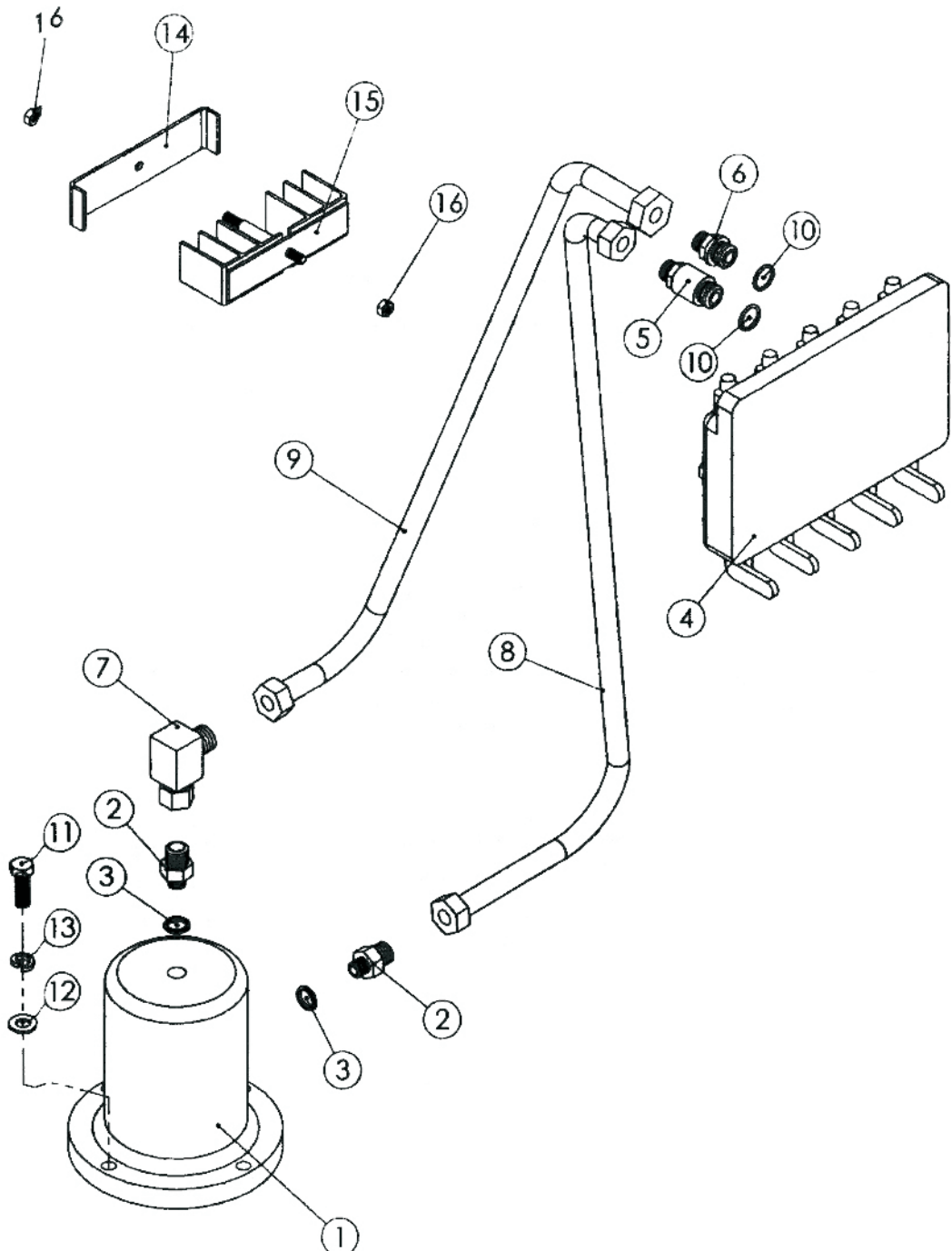

35- Sistema Hidráulico de Trabajo 3

CODIGO DOWEL	PIEZA	DESCRIPCION	CANT.
MM165.35.001	1	CILINDRO DE RIPEADOR	1
MM165.35.002	2	ARANDELA COMBINADA	2
MM165.35.003	3	ACOPLE A CILINDRO	2
MM165.33.005	4	CODO CONECTOR	2
	5	MANGUERA AC. HIDR.	1
	6	MANGUERA AC. HIDR.	1
MM165.35.007	7	ACOPLE DE MANGUERA	1
MM165.33.008	8	CONECTOR	1
MM165.33.009	9	O-RING 19x2.46	2
MM165.35.010	10	VALVULA DE COMANDO	1

35- Sistema Hidráulico de Trabajo 3

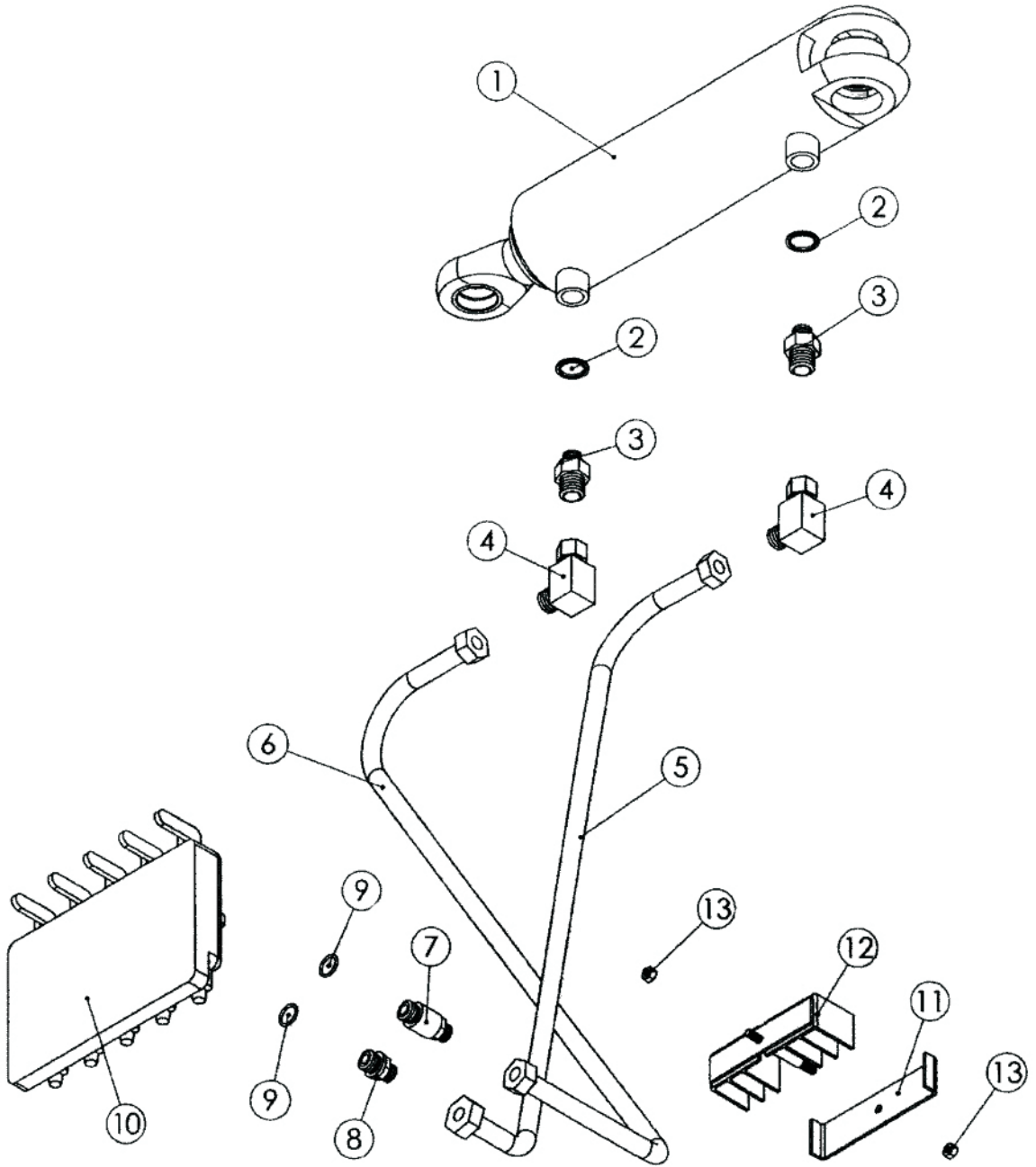

36- Sistema Hidráulico de Trabajo 4

CODIGO DOWEL	PIEZA	DESCRIPCION	CANT.
MM165.35.010	1	VALVULA DE COMANDO	1
MM165.35.007	2	ACOPLE DE MANGUERA	1
MM165.33.008	3	CONECTOR	1
MM165.33.009	4	O-RING 19x2.46	2
MM165.33.012	12	ACOPLE "T" CC-22	1
MM165.36.006	6	CONECTOR	2
MM165.33.005	7	CODO CONECTOR	2
MM165.36.008	8	CILINDRO ARTICULACION IZQ.	1
	9	MANGUERA AC. HIDR.	2
	10	MANGUERA AC. HIDR.	1
	11	MANGUERA AC. HIDR.	1
MM165.36.012	12	PERNO DE CILINDRO ARTIC	4
	13	TORNILLO DE PERNO	4
	14	TUERCA	4
	15	ARANDELA DE PERNO CILINDRO	4
MM165.36.016	16	CILINDRO ARTICULACION DER.	1
MM165.33.017	17	ABRZADERA MANGERA, ASIENTO	1
MM165.33.018	18	ABRZADERA MANGERA, TAPA	1
	19	TUERCA M8	2

36- Sistema Hidráulico de Trabajo 4

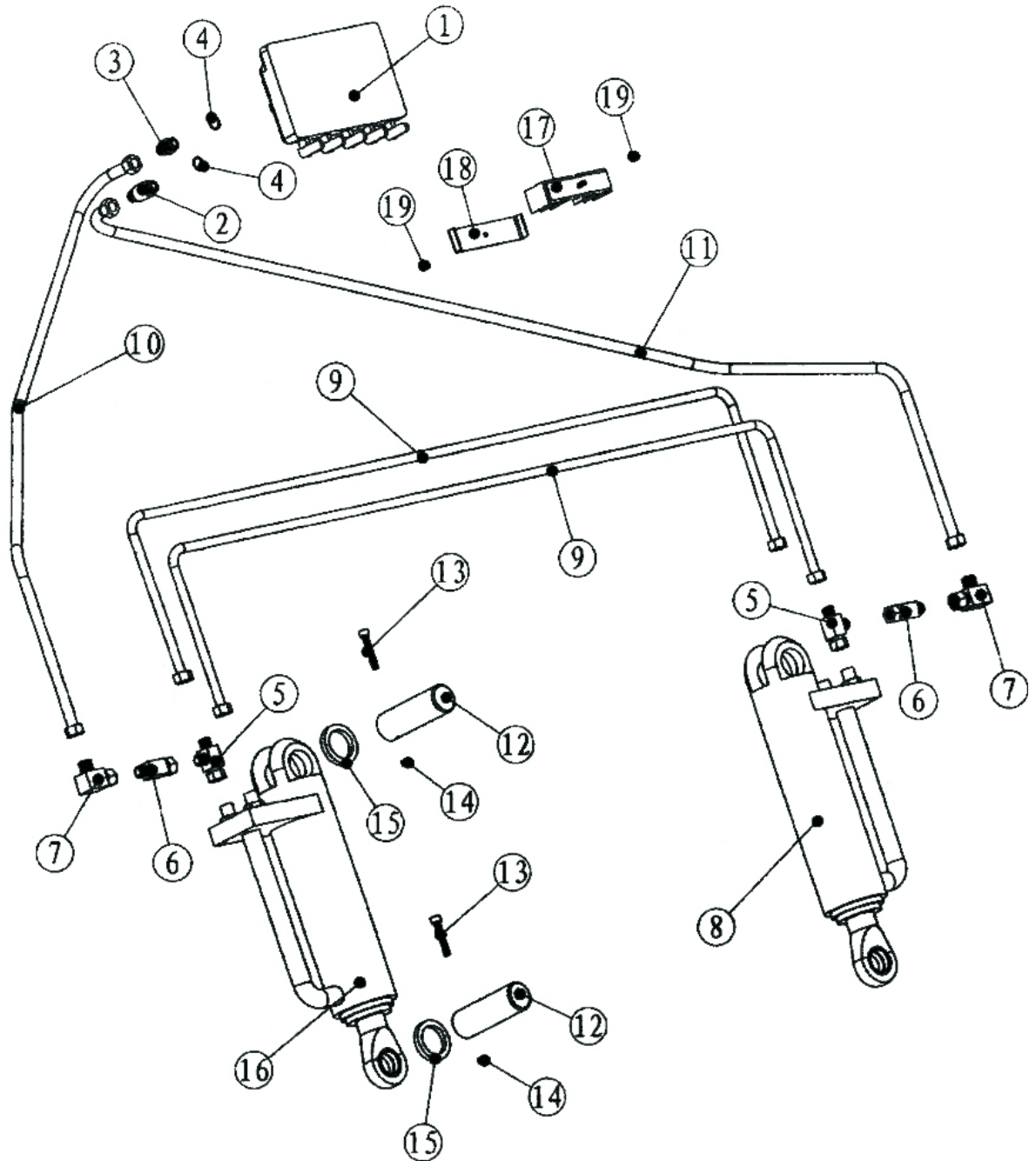

37- Sistema Hidráulico de Trabajo 5

CODIGO DOWEL	PIEZA	DESCRIPCION	CANT.
MM165.37.001	1	CILINDRO BALANCEO DE HOJA	1
MM165.37.002	2	TRABA HIDRAULICA 2 VIAS SYS-L10H3	1
MM165.37.003	3	VALVULA MULTVIA	1
MM165.37.004	4		1
MM165.37.005	5		1
MM165.37.006	6		2
MM165.37.007	7		2
MM165.37.008	8		2
MM165.37.009	9		2
MM165.37.010	10		4
	11		3
	12		3
	13		1
	14		1
	15		1
	16		1
MM165.33.017	17	ABRZADERA MANGERA, ASIENTO	1
MM165.33.018	18	ABRZADERA MANGERA, TAPA	1
	19	TUERCA M8	2

37- Sistema Hidráulico de Trabajo 5

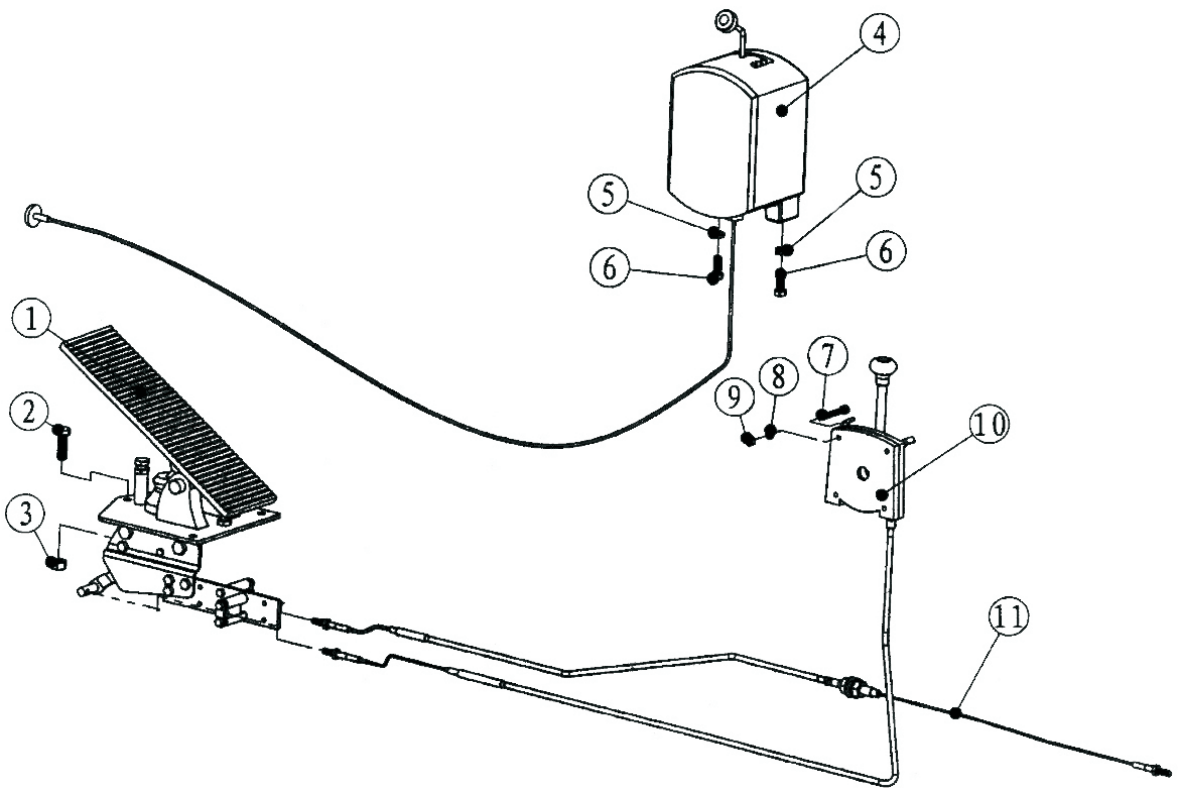

38- Sistema Hidráulico de Trabajo 6

CODIGO DOWEL	PIEZA	DESCRIPCION	CANT.
MM165.38.001	1	CILINDRO HORIZONTAL DE HOJA	1
MM165.38.002	2	UNION ROTATIVA	1
MM165.38.003	3	CONECTOR	2
	4	MANGUERA AC. HIDR.	2
MM165.38.005	5	CONECTOR	2
MM165.33.005	6	CODO CONECTOR	2
MM165.35.010	7	VALVULA DE COMANDO	1
MM165.34.005	8	CONECTOR	1
MM165.33.008	9	CONECTOR	1
MM165.33.009	10	O-RING 19x2.46	2
	11	MANGUERA AC. HIDR.	1
	12	MANGUERA AC. HIDR.	1
	13	BULON M8x25	3
	14	ARANDELA 8	3
	15	ARANDELA 8	4
	16	BULON M6x25	4
MM165.33.017	17	ABRZADERA MANGERA, ASIENTO	1
MM165.33.018	18	ABRZADERA MANGERA, TAPA	1
	19	TUERCA M8	2

38- Sistema Hidráulico de Trabajo 6

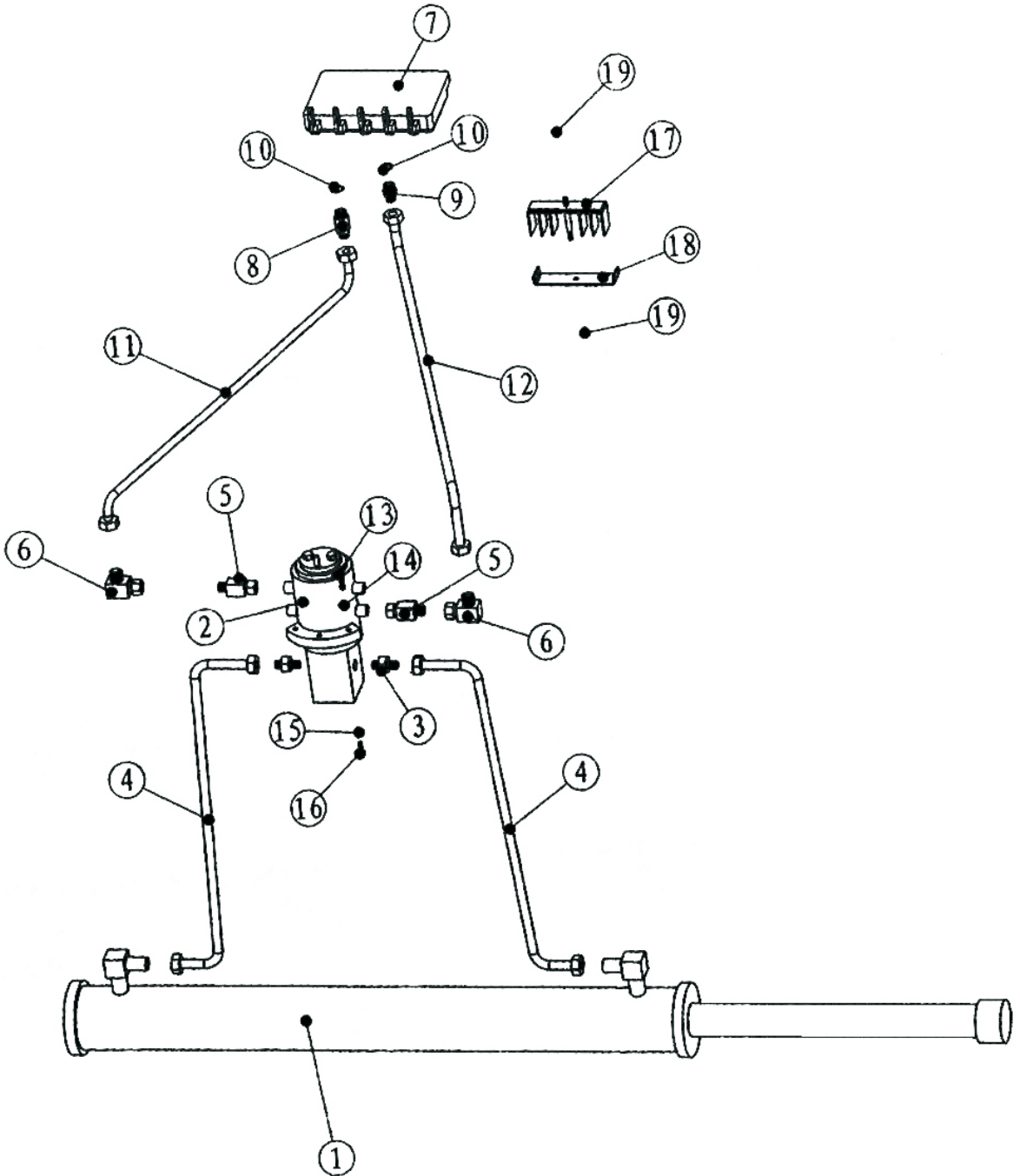

39- Sistema Hidráulico de Trabajo 7

CODIGO DOWEL	PIEZA	DESCRIPCION	CANT.
MM165.38.002	1	UNION ROTATIVA	1
MM165.35.010	2	VALVULA DE COMANDO	1
MM165.38.003	3	CONECTOR	4
MM165.38.005	4	CONECTOR	2
MM165.33.005	5	CODO CONECTOR	2
MM165.34.005	6	CONECTOR	1
MM165.33.008	7	CONECTOR	1
MM165.33.009	8	O-RING 19x2.46	2
	9	BULON M8x25	3
	10	ARANDELA 8	3
	11	ARANDELA 6	4
	12	BULON M6x20	4
MM165.39.013	13	CILINDRO INCLINACION DE HOJA	2
	14	MANGUERA AC. HIDR.	2
	15	MANGUERA AC. HIDR.	2
	16	MANGUERA AC. HIDR.	1
	17	MANGUERA AC. HIDR.	1
MM165.33.017	18	ABRZADERA MANGERA, ASIENTO	1
MM165.33.018	19	ABRZADERA MANGERA, TAPA	1
	20	TUERCA M8	2

39- Sistema Hidráulico de Trabajo 7

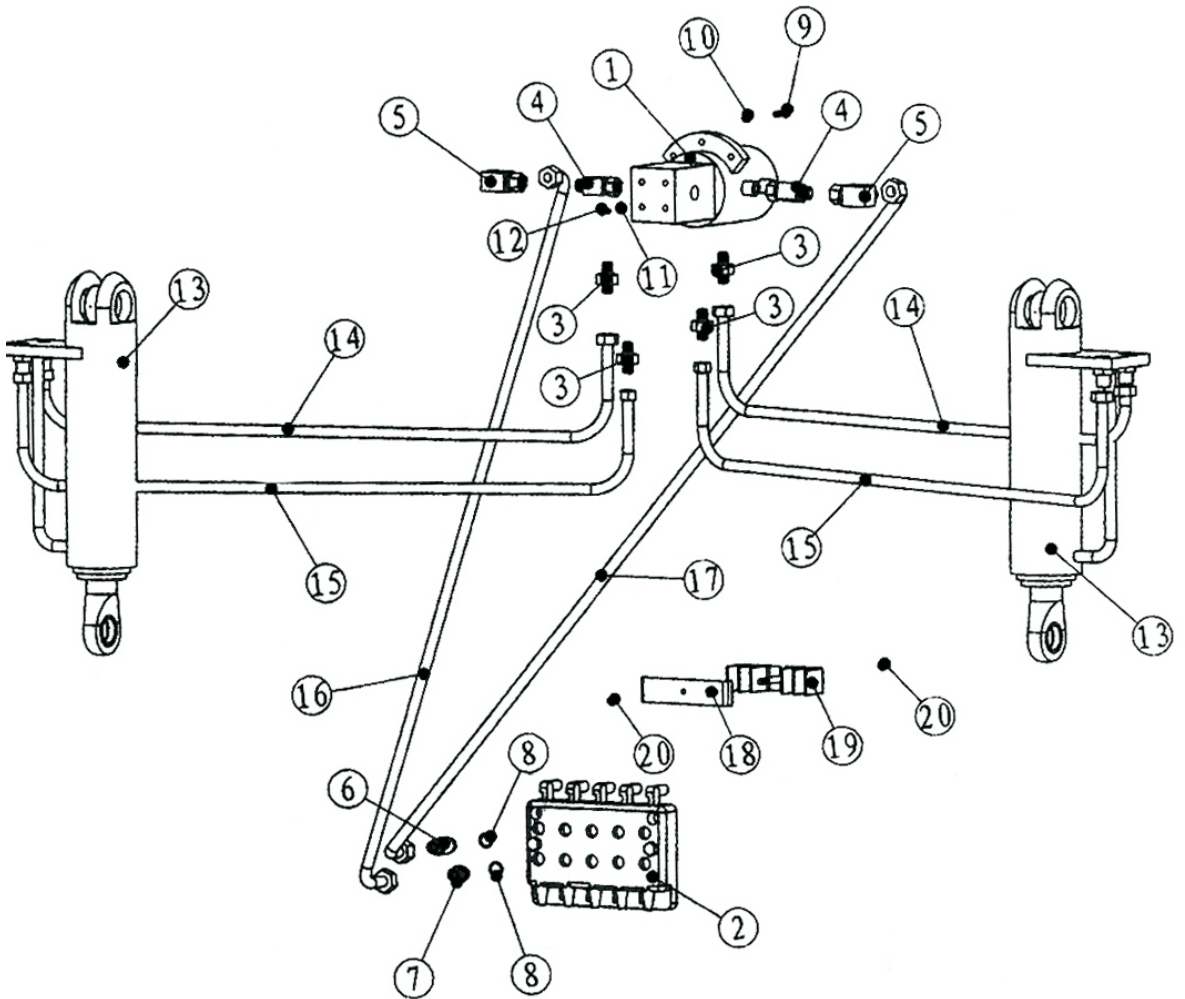

40- Sistema Hidráulico de Trabajo 8

CODIGO DOWEL	PIEZA	DESCRIPCION	CANT.
MM165.40.001	1	CILINDRO FRONTAL	1
MM165.35.002	2	ARANDELA COMBINADA	2
MM165.35.003	3	ACOPLE A CILINDRO	2
MM165.35.010	4	VALVULA DE COMANDO	1
MM165.34.005	5	CONECTOR	1
MM165.33.008	6	CONECTOR	1
MM165.33.005	7	CODO CONECTOR	2
MM165.40.008	8	MANGUERA A.C. HIDR.	1
MM165.40.009	9	MANGUERA A.C. HIDR.	1
MM165.33.009	10	O-RING 19x2.46	2
MM165.33.017	11	ABRZADERA MANGERA, ASIENTO	1
MM165.33.018	12	ABRZADERA MANGERA, TAPA	1
MM165.34.016	13	TUERCA M8	2

40- Sistema Hidráulico de Trabajo 8

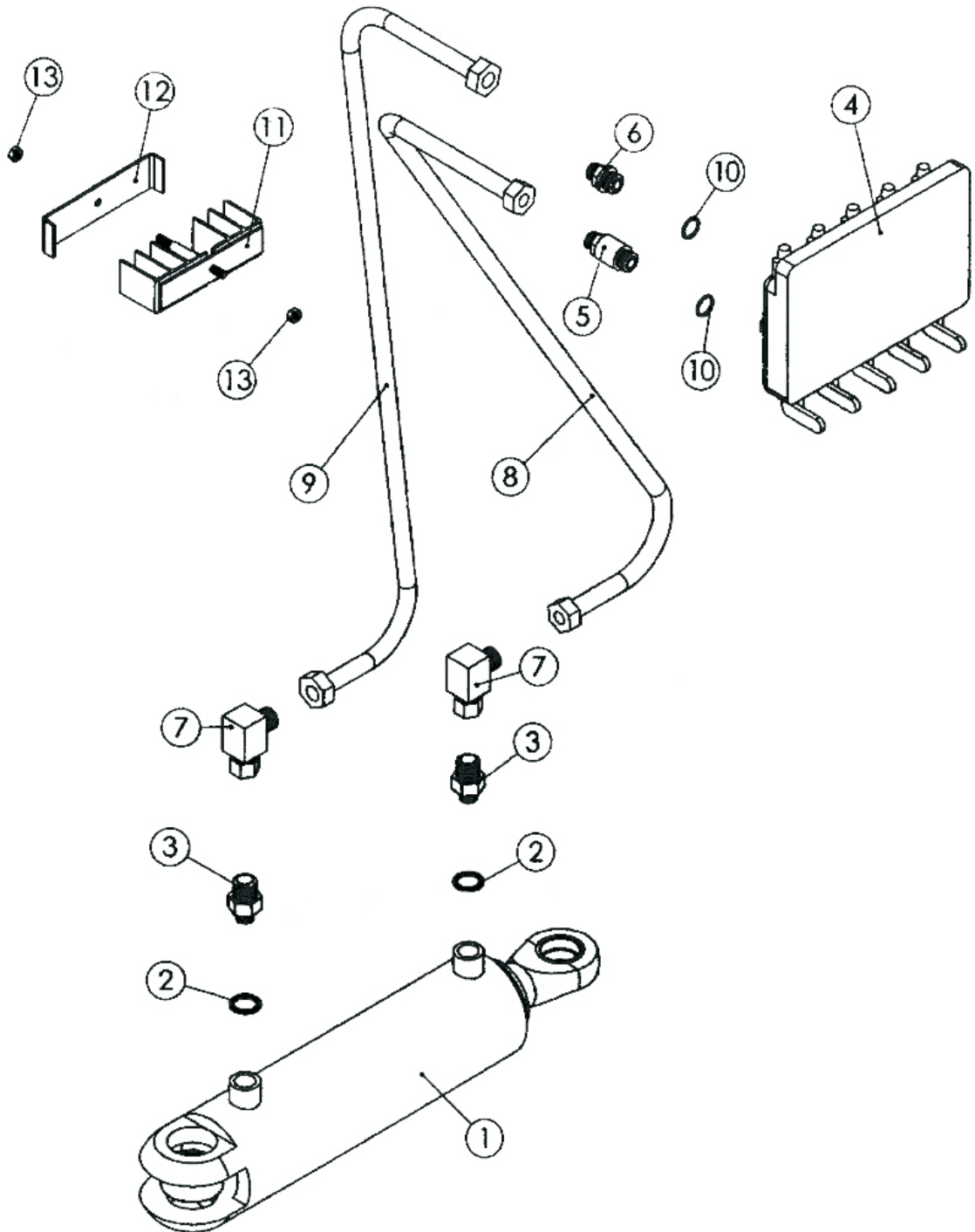

41- Sistema Hidráulico de Trabajo 9

CODIGO DOWEL	PIEZA	DESCRIPCION	CANT.
MM165.41.001	1	CILINDRO ELEVACION HOJA	1
MM165.41.002	2	CILINDRO ELEVACION HOJA	1
MM165.41.003	3	ABRAZADERA	4
MM165.41.004	4	SOPORTE	2
MM165.41.005	5	BULON M8x25	4
MM165.41.006	6	TUERCA M8	8
MM165.41.007	7	VALVULA DE BALANCE	2
MM165.41.008	8	CONECTOR	4
MM165.41.009	9	BULON	4
MM165.35.002	10	ARANDELA COMBINADA	8
MM165.41.011	11	TORNILLO M8x70	6
MM165.41.012	12	ARANDELA 8	6
MM165.41.013	15	UNION ANGULO	2
MM165.41.014	16	UNION ANGULO	2
MM165.41.015	17	MANGUERA AC. HIDR.	4
MM165.41.016	18	MANGUERA AC. HIDR.	2
MM165.41.017	19	MANGUERA AC. HIDR.	2
MM165.35.010	20	VALVULA DE COMANDO	2
MM165.34.005	21	CONECTOR	2
MM165.33.008	22	CONECTOR	2
MM165.33.009	23	O-RING 19x2.46	4
MM165.33.018	24	ABRZADERA MANGERA, TAPA	2
MM165.33.017	25	ABRZADERA MANGERA, ASIENTO	2

41- Sistema Hidráulico de Trabajo 9

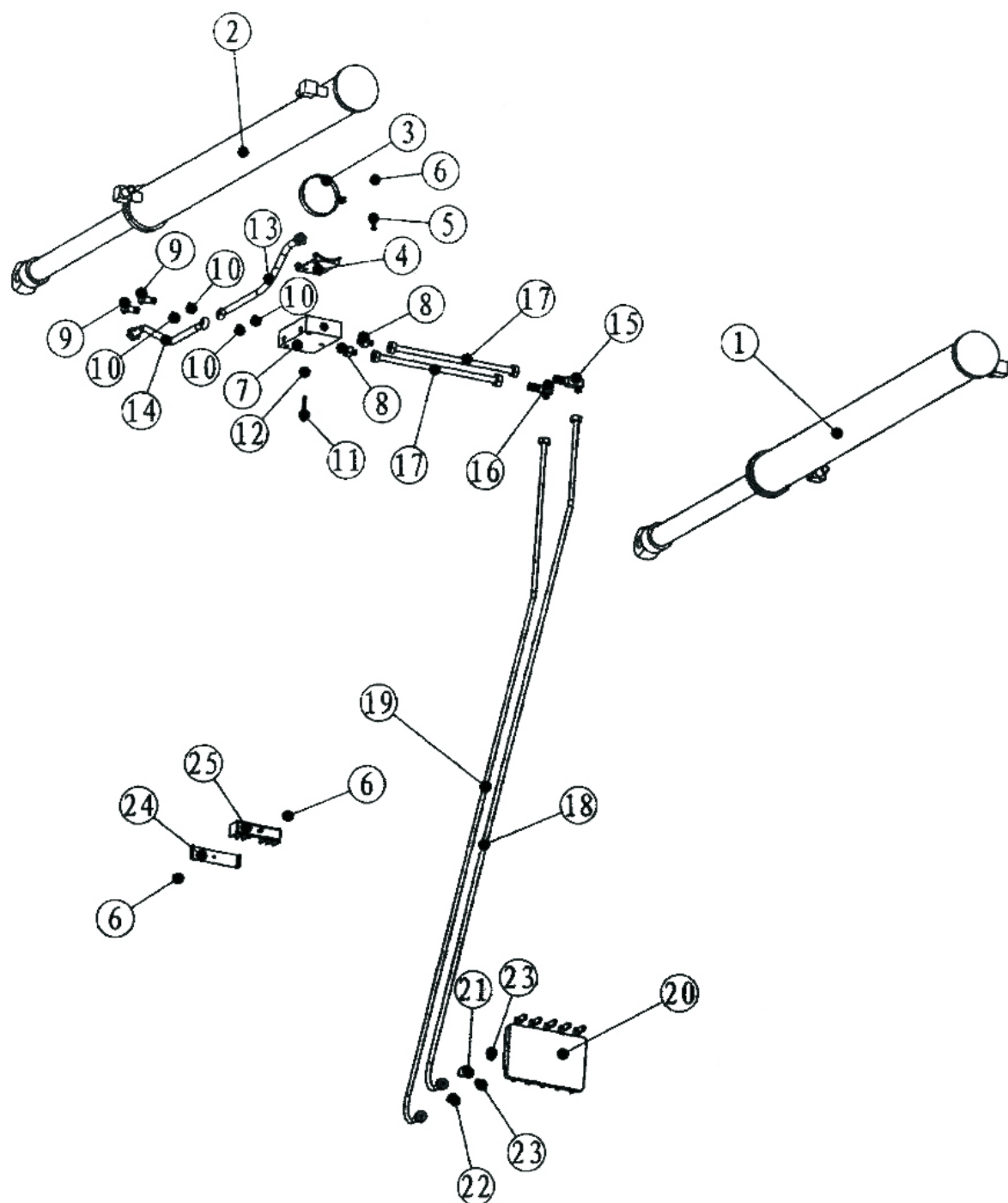

42- Sistema Hidráulico de Trabajo 10

CODIGO DOWEL	PIEZA	DESCRIPCION	CANT.
MM165.35.010	1	VALVULA DE COMANDO DERECHA	1
MM165.42.002	2	CONACTOR	2
MM165.42.003	3	CONACTOR	2
	4	MANGUERA AC. HIDR.	1
	5	MANGUERA AC. HIDR.	1
MM165.35.010	6	VALVULA DE COMANDO IZQUIERDA	1
	7	MANGUERA AC. HIDR.	1
	8	MANGUERA AC. HIDR.	1

42- Sistema Hidráulico de Trabajo 10

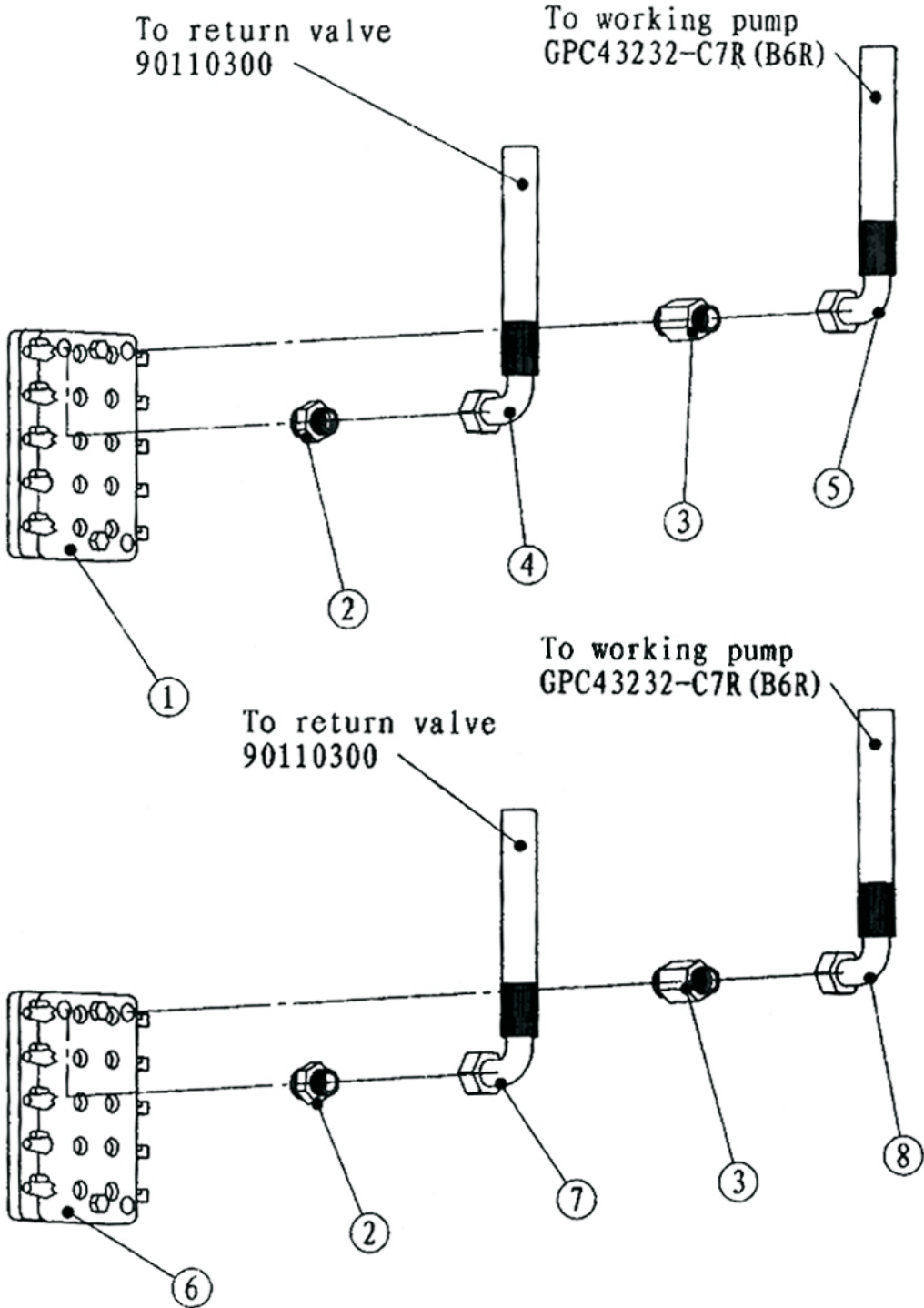

43- Sistema de Dirección Hidráulico 1

CODIGO DOWEL	PIEZA	DESCRIPCION	CANT.
MM165.33.002	1	TANQUE DE ACEITE HIDRAULICO	1
MM165.43.002	2	BOMBA HIDRAULICA	1
MM165.43.003	3	VALVULA TIPO "T"	1
	4	MANGUERA AC. HIDR.	1
MM165.43.005	5	UNIDAD DE DIRECCION	1
	6	MANGUERA AC. HIDR.	1
MM165.33.012	12	ACOPLE "T" CC-22	1
	8	MANGUERA AC. HIDR.	1
	9	MANGUERA AC. HIDR.	1
	10	MANGUERA AC. HIDR.	1
MM165.43.011	11	CODO CONECTOR	2
MM165.43.012	12	CILINDRO DE DIRECCION IZQ.	1
MM165.43.013	13	CONECTOR	4
MM165.43.014	14	CILINDRO DE DIRECCION DER.	1
MM165.43.015	15	MANGUERA AC. HIDR.	2
MM165.43.016	16	BULON M20x1.5	4
MM165.43.017	17	ARANDELA COMBINADA 20	8
MM165.43.018	18	ARANDELA COMBINADA 14	4
MM165.43.020		VOLANTE DE MANEJO	1

43- Sistema de Dirección Hidráulico 1

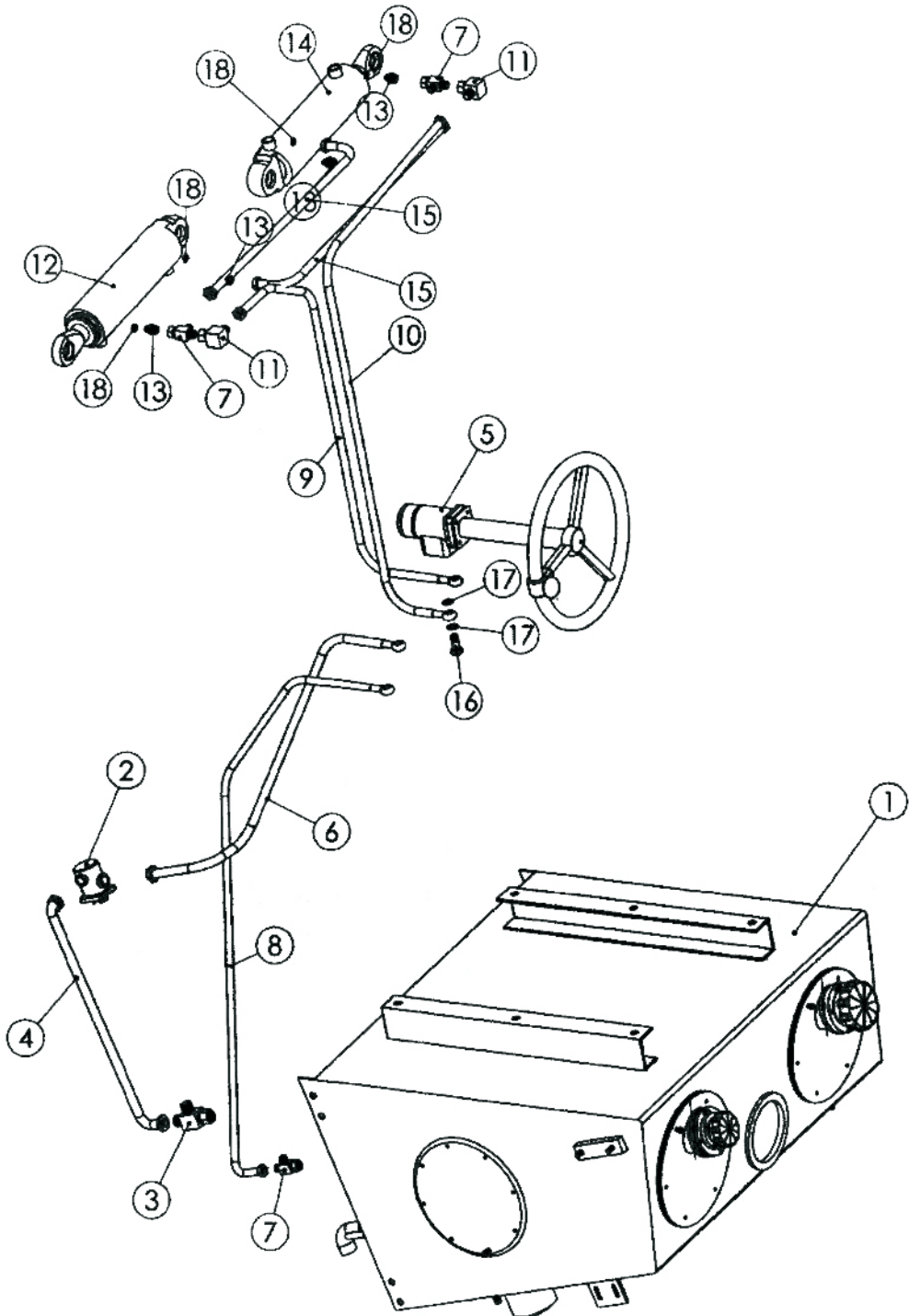

44- Sistema de Dirección Hidráulico 2

CODIGO DOWEL	PIEZA	DESCRIPCION	CANT.
MM165.44.001	1	CILINDRO DE BALANCEO RUEDA	1
MM165.35.003	2	ACOPLE A CILINDRO	2
MM165.44.003	3	VALVULA TIPO "T"	1
MM165.44.004	4	VALVULA DE DOS VIAS	1
	5	MANGUERA AC. HIDR.	1
MM165.44.006	6	CONECTOR	4
MM165.44.007	7	ARANDELA COMBINADA 22	4
	8	MANGUERA AC. HIDR.	1
MM165.44.009	9	TORNILLO M8x70	3
MM165.44.010	10	ARANDELA 8	3
MM165.44.011	11	ARANDELA 8	3
MM165.35.010	12	VALVULA DE COMANDO	1
MM165.36.006	13	CONECTOR	2
	14	MANGUERA AC. HIDR.	1
MM165.33.008	15	CONECTOR	1
MM165.33.009	16	O-RING 19x2.46	2
MM165.34.005	17	CONECTOR	1
	18	MANGUERA AC. HIDR.	1

44- Sistema de Dirección Hidráulico 2

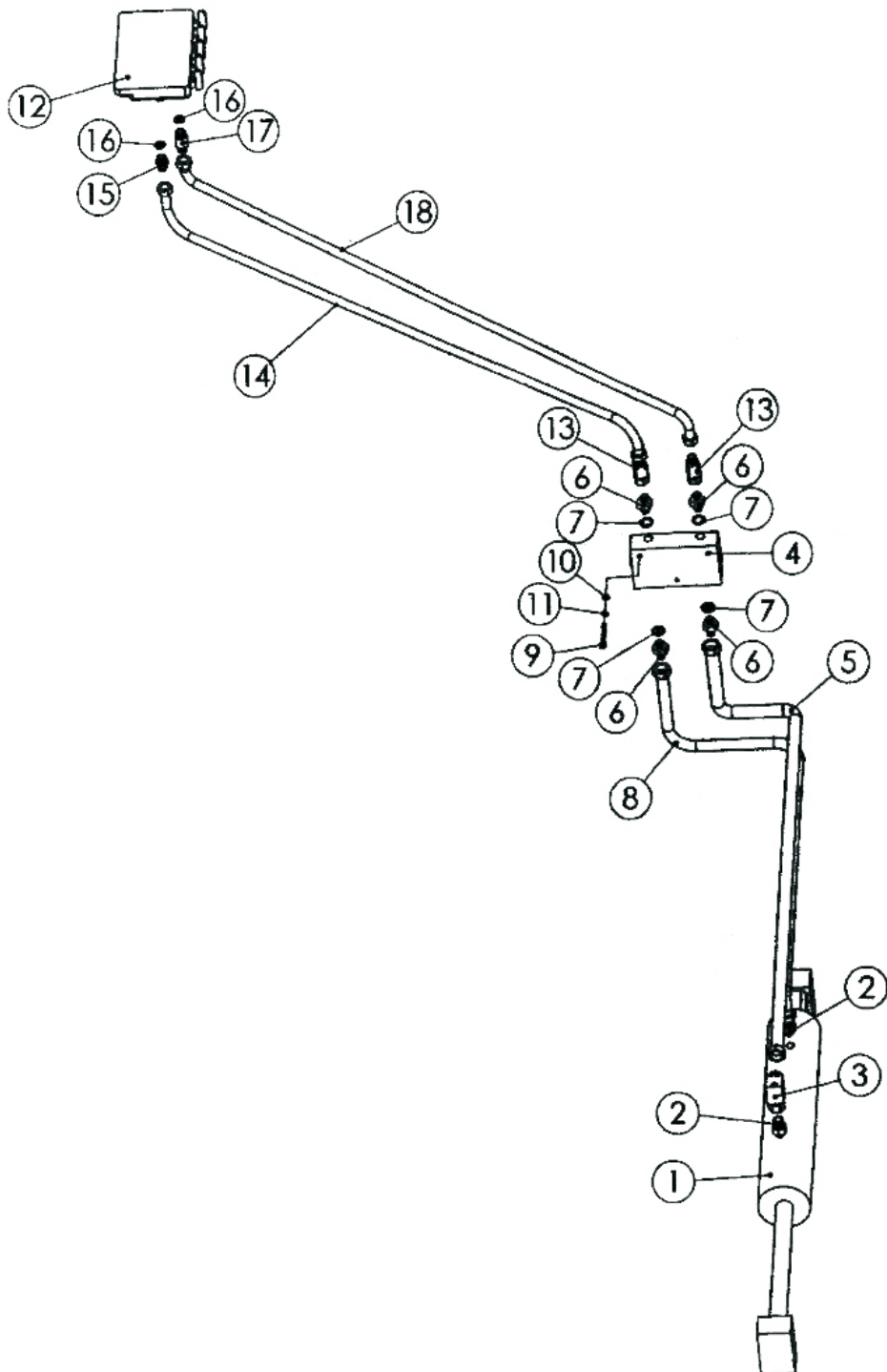

46- Columna de Dirección Completa

CODIGO DOWEL	PIEZA	DESCRIPCION	CANT.
MM165.46.001	1	VOLANTE DE MANEJO	1
MM165.46.002	2	UNIDAD CONTROL DE DIRECCION	1
MM165.46.003	3	TAPA DE VOLANTE	1
MM165.46.004	4	COLUMNA DE DIRECCION	1
MM165.46.005	5	TORNILLO M6x35	1
MM165.46.006	6	ARANDELA 12	4
MM165.46.007	7	ARANDELA 12	1
MM165.46.008	8	BULON M12x30	4
MM165.46.009	9	TUERCA M12	1
MM165.46.010	10	PERNO	4
MM165.46.011	11	ARANDELA JUNTA	8

46- Columna de Dirección Completa

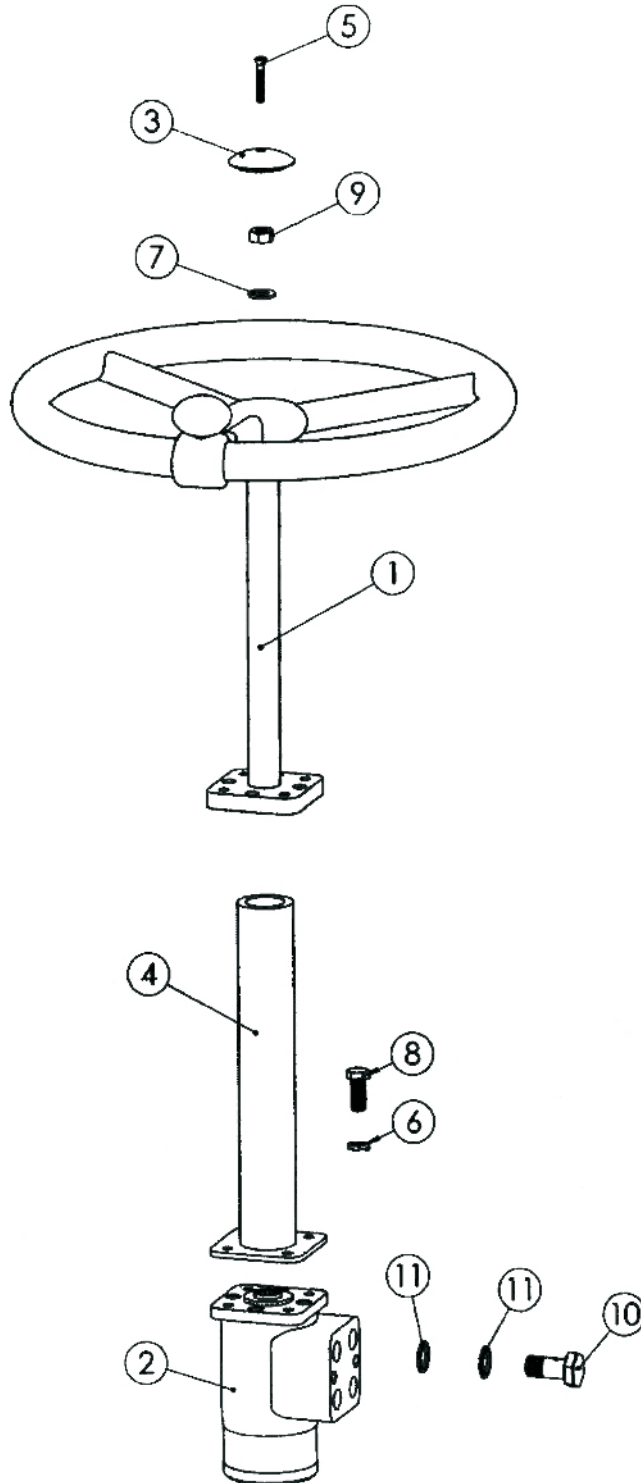

47- Tanque de Aceite

CODIGO DOWEL	PIEZA	DESCRIPCION	CANT.
MM165.47.001	1	TANQUE DE ACEITE HIDRAULICO	1
MM165.47.002	2	TAPA SUPERIOR TANQUE AC.	2
MM165.47.003	3	O-RING 265 X 7	4
MM165.47.004	4	BULON M8x18	12
MM165.47.005	5	ARANDELA 8	28
MM165.47.006	6	PLACA DE TAPA SUP. TANQUE	1
MM165.47.007	7	JUNTA DE GOMA	1
MM165.47.009	9	ORIENTABLE P/NIVEL ACEITE	2
MM165.47.010	10	FILTRO DE BOCA TANQUE	1
MM165.47.011	11	BULON M14x16	6
MM165.47.012	12	ARANDELA 4	6
MM165.47.013	13	FILTRO DE BOCA TANQUE	1
MM165.47.014	14	LLAVE PASO ACEITE	1
MM165.47.015	15	TUBO DESCARGA ACEITE	1
MM165.47.016	16	CONECTOR	2
MM165.47.017	17	TUBO SUCCION ACEITE	2
MM165.47.018	18	TAPA LA TERAL TANQUE	2
MM165.47.019	19	BULON M8x25	16
MM165.47.020	20	FILTRO SUCCION ACEITE	1
MM165.47.021	21	FILTRO SUCCION ACEITE	1
MM165.47.022	22	TAPON DE ACEITE	1
MM165.47.023	23	ARANDELA COMBINADA 22	1
MM165.47.024	24	FILTRO RETORNO ACEITE	1
MM165.47.025	25	BULON M10x6	4
MM165.47.026	26	ARANDELA 10	4

47- Tanque de Aceite

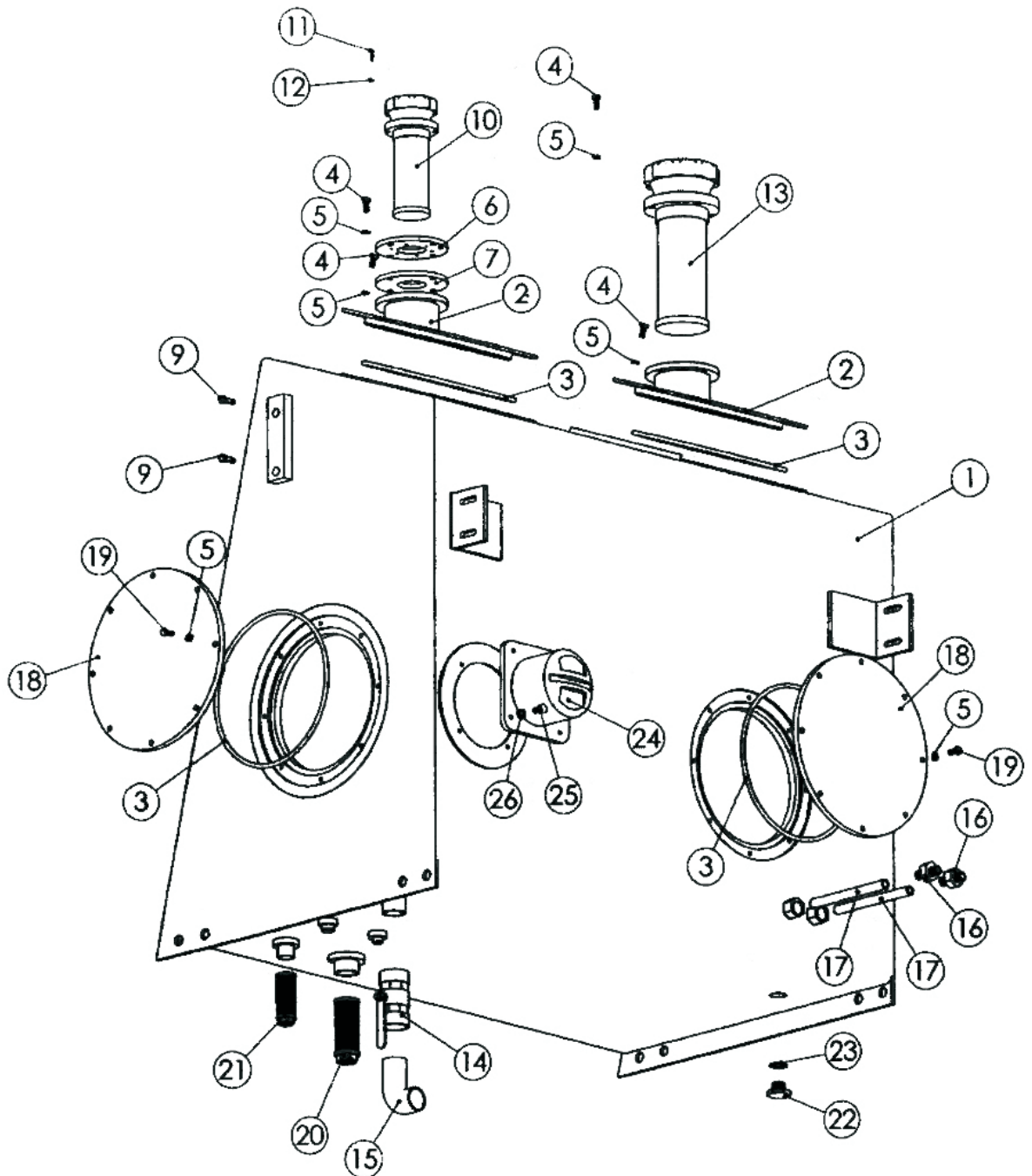

48- Cabina

CODIGO DOWEL	PIEZA	DESCRIPCION	CANT.
MM165.48.001	1	ARANDELA 16	8
MM165.48.002	2	ARANDELA 16	8
MM165.48.003	3	BULON M16x40	8
MM165.48.004	4	ESCALERA	2
MM165.48.005	5	ARANDELA 12	6
MM165.48.006	6	ARANDELA 12	6
MM165.48.007	7	BULON M12x25	6
MM165.48.008	8	CABINA COMPLETA	1
MM165.48.009	9	BURLETE	2

48- Cabina

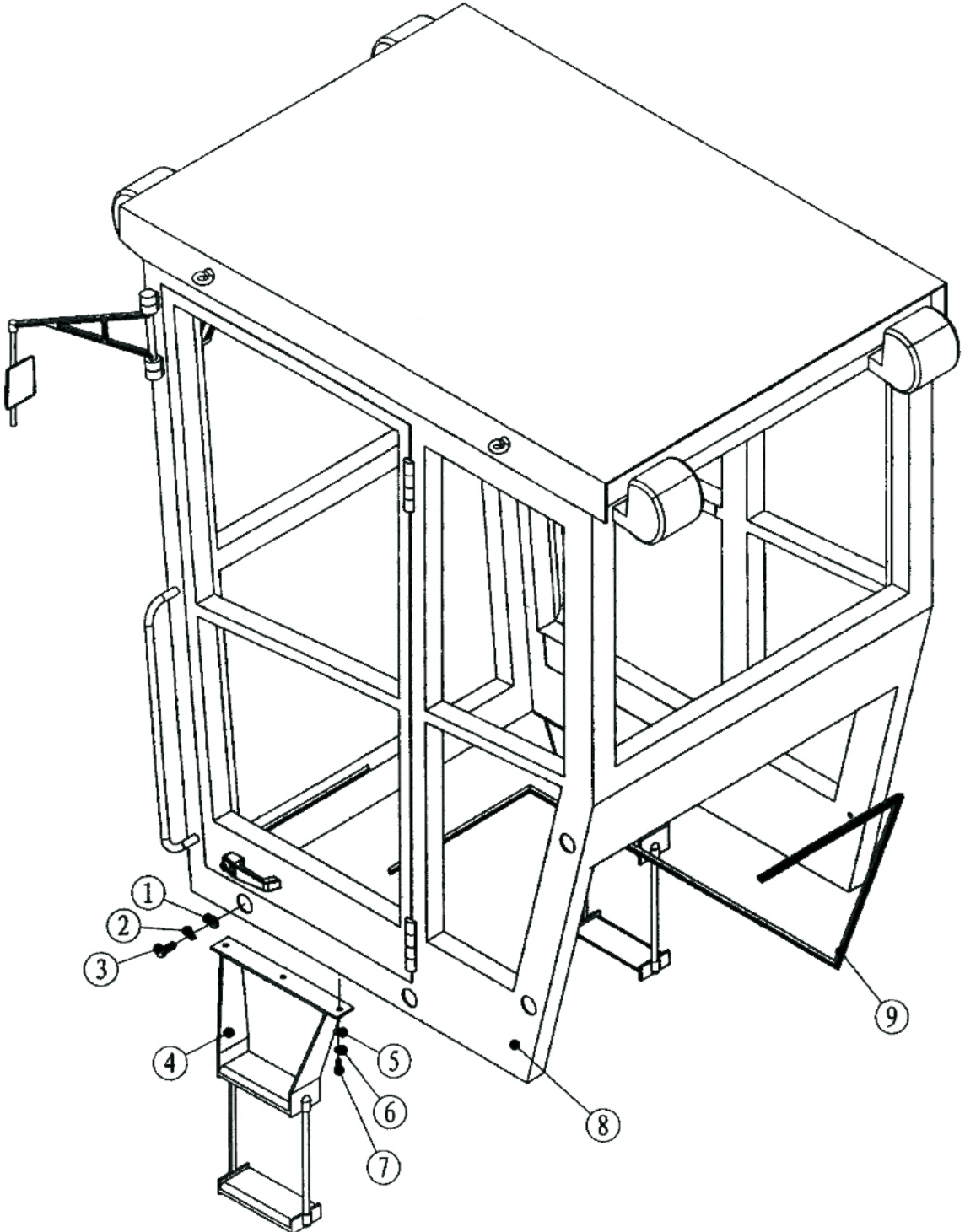

49- Sistema Eléctrico

CODIGO DOWEL	PIEZA	DESCRIPCION
MM165.49.001	1	FUSIBLERA
MM165.49.002	2	DESTELLADOR
MM165.49.003	3	FUSIBLE 40A
MM165.49.004	4	VOLTIMETRO
MM165.49.005	5	MEDIDOR PRESION ACEITE
MM165.49.006	6	MEDIDOR TEMP. AGUA
MM165.49.007	7	
MM165.49.008	8	TACOMETRO
MM165.49.009	9	MEDIDOR PRESION AIRE
MM165.49.010	10	SENSOR PRESION ACEITE MOTOR
MM165.49.011	11	SENSOR PRESION AIRE
MM165.49.012	12	SENSOR DE FILTRO AIRE
MM165.49.013	13	SENSOR TEMP AGUA
MM165.49.014	14	SENSOR FILTRO ACEITE HIDR
MM165.49.015	15	SENSOR RETORNO FILTRO ACEITE HIDR
MM165.49.016	16	SENSOR ENTRADA FILTRO ACEITE HIDR
MM165.49.017	17	SENSOR PRESION MEDIDOR ACEITE MOTOR
MM165.49.018	18	SENSOR TEMP MEDIDOR AGUA MOTOR
MM165.49.019	19	
MM165.49.020	20	SENSOR DE TACOMETRO
MM165.49.021	21	SENSOR PRESION AIRE
MM165.49.022	22	BOCINA
MM165.49.023	23	LAMPARA DEL. IZQ. POSICION
MM165.49.024	24	LAMPARA TRAS. DER. POSICION
MM165.49.025	25	LAMPARA TRAS. IZQ. POSICION
MM165.49.026	26	LAMPARA DEL. DER. DIRECCION
MM165.49.027	27	LAMPARA DEL. IZQ. DIRECCION
MM165.49.028	28	LAMPARA TRAS. DER. DIRECCION
MM165.49.029	29	LAMPARA DEL IZQ. DE TRABAJO
MM165.49.030	30	LAMPARA DEL DER. DE TRABAJO
MM165.49.031	31	LAMPARA TRAS. IZQ. DE TRABAJO

49- Sistema Eléctrico

CODIGO DOWEL	PIEZA	DESCRIPCION
MM165.49.032	32	LAMPARA TRAS. DER. DE TRABAJO
MM165.49.033	33	LAMPARA TECHO CABINA
MM165.49.034	34	LUZ DE VOLTIMETRO
MM165.49.035	35	LUZ DE VOLTIMETRO
MM165.49.036	36	LAMPARA TEMP A GUA
MM165.49.037	37	LUZ NIVEL COMBUST
MM165.49.038	38	LUZ DE TACOMETRO
MM165.49.039	39	LUZ DE MANOMETRO
MM165.49.040	40	LUZ ADVERTENCIA BAJA PRESION ACEITE
MM165.49.041	41	
MM165.49.042	42	LUZ ADVERTENCIA FILTRO AIRE MOTOR
MM165.49.043	43	LUZ ADVERTENCIA SOBRECALENTAMIENTO
MM165.49.044	44	LUZ ADVERT. FILTRO A.C. HIDR.
MM165.49.045	45	LUZ ADVERT. FILTRO REORNO A.C. HIDR.
MM165.49.046	46	LUZ ADVERT. FILTRO ENTRADA A.C. HIDR.
MM165.49.047	47	INTERRUPTOR ENCEDIDO ELECTRICO
MM165.49.048	48	RELAY DE ARRANQUE
MM165.49.049	49	RELAY DE BOCINA
MM165.49.050	50	RELAY LAMAPARA DEL Y TRAS TRABAJO
MM165.49.051	51	RELAY DE COMPRESOR AIRE ACOND.
MM165.49.052	52	RELAY DE VENTILADOR AIRE ACOND.
MM165.49.053	53	INTERRUPTOR ENCENDIDO MOTOR
MM165.49.054	54	BOTON DE BOCINA
MM165.49.055	55	SELECTOR DE VELOCIDAD
MM165.49.056	56	INTERRUPTOR LAMPARA DIRECC IZQ
MM165.49.057	57	INTERRUPTOR LAMPARA DIRECC DER
MM165.49.058	58	INTERRUPTOR LAMPARA DELANT. TRABAJO
MM165.49.059	59	INTERRUPTOR LAMPARA TRAS. TRABAJO
MM165.49.060	60	INTERRUPTOR LAMPARA CABINA
MM165.49.061	61	INTERRUPTOR LIMPIA PARABRISA
MM165.49.062	62	INTERRUPTOR VENTILADOR CABINA
MM165.49.063	63	INTERRUPTOR AIRE A CONDIC.
MM165.49.064	64	DIODO
MM165.49.065	65	DIODO
MM165.49.066	66	ALOJAMIENTO DE BATERIA
MM165.49.067	67	ALTERNADOR
MM165.49.068	68	MOTOR DE ARRANQUE
MM165.49.069	69	MOTOR DE LIMPIA PARABRISA
MM165.49.070	70	MOTOR VENTILADOR CABINA
MM165.49.071	71	COMPRESOR AIRE A CONDIC.
MM165.49.072	72	VENTILADOR AIRE ACONDICIONADO
MM165.49.073	73	PA RE ELECTRICO
MM165.49.074	74	SOLENOIDE DE SELECTOR VELOCIDAD

49- Sistema Eléctrico

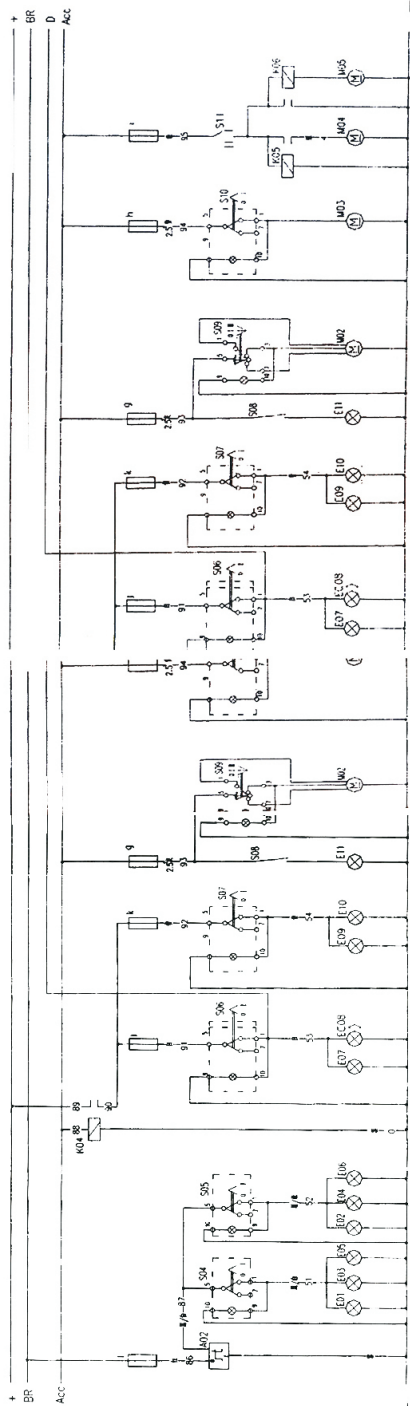
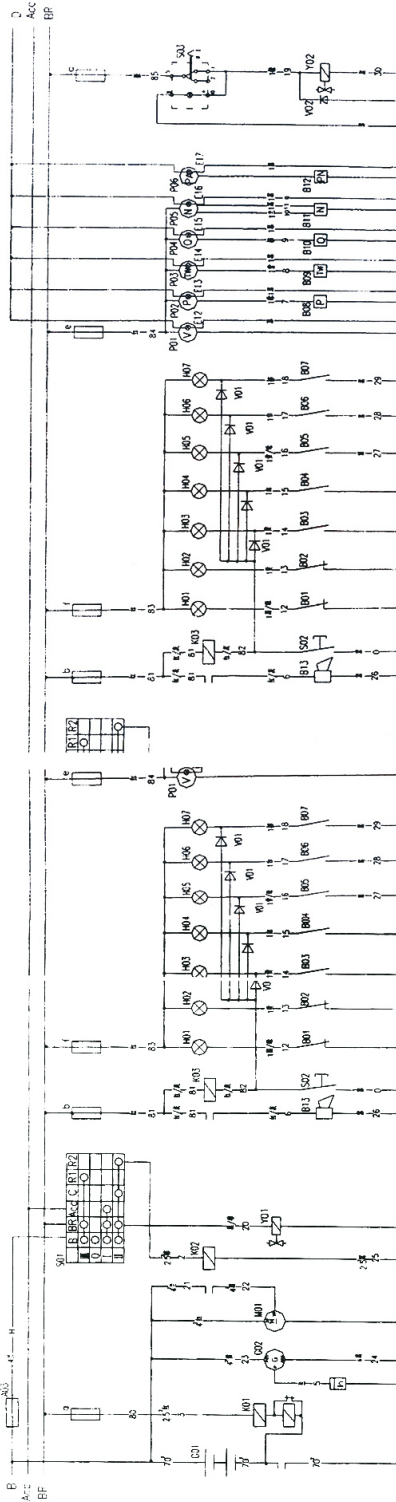



MICHIGAN[®]